

LAMPIRAN

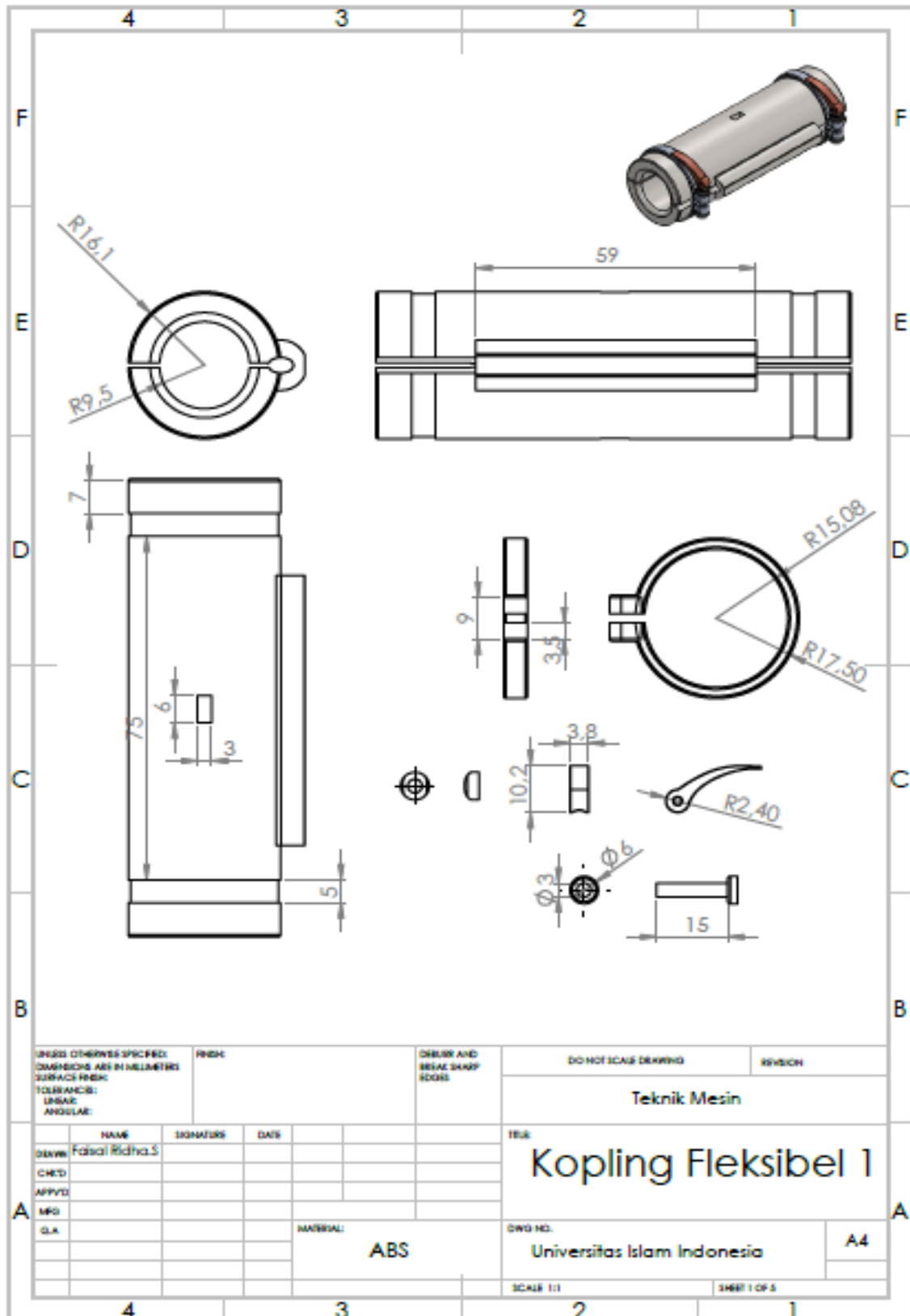

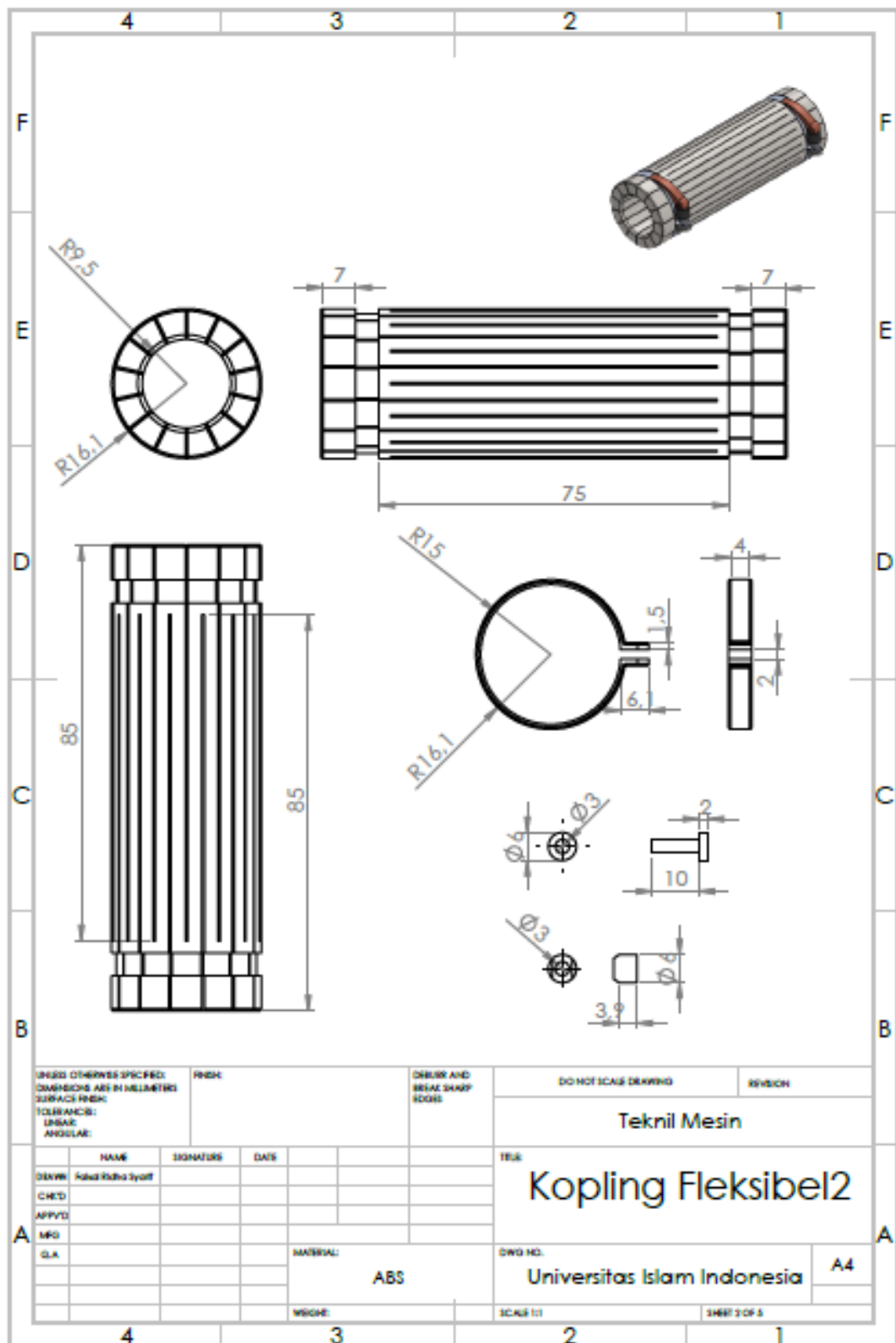

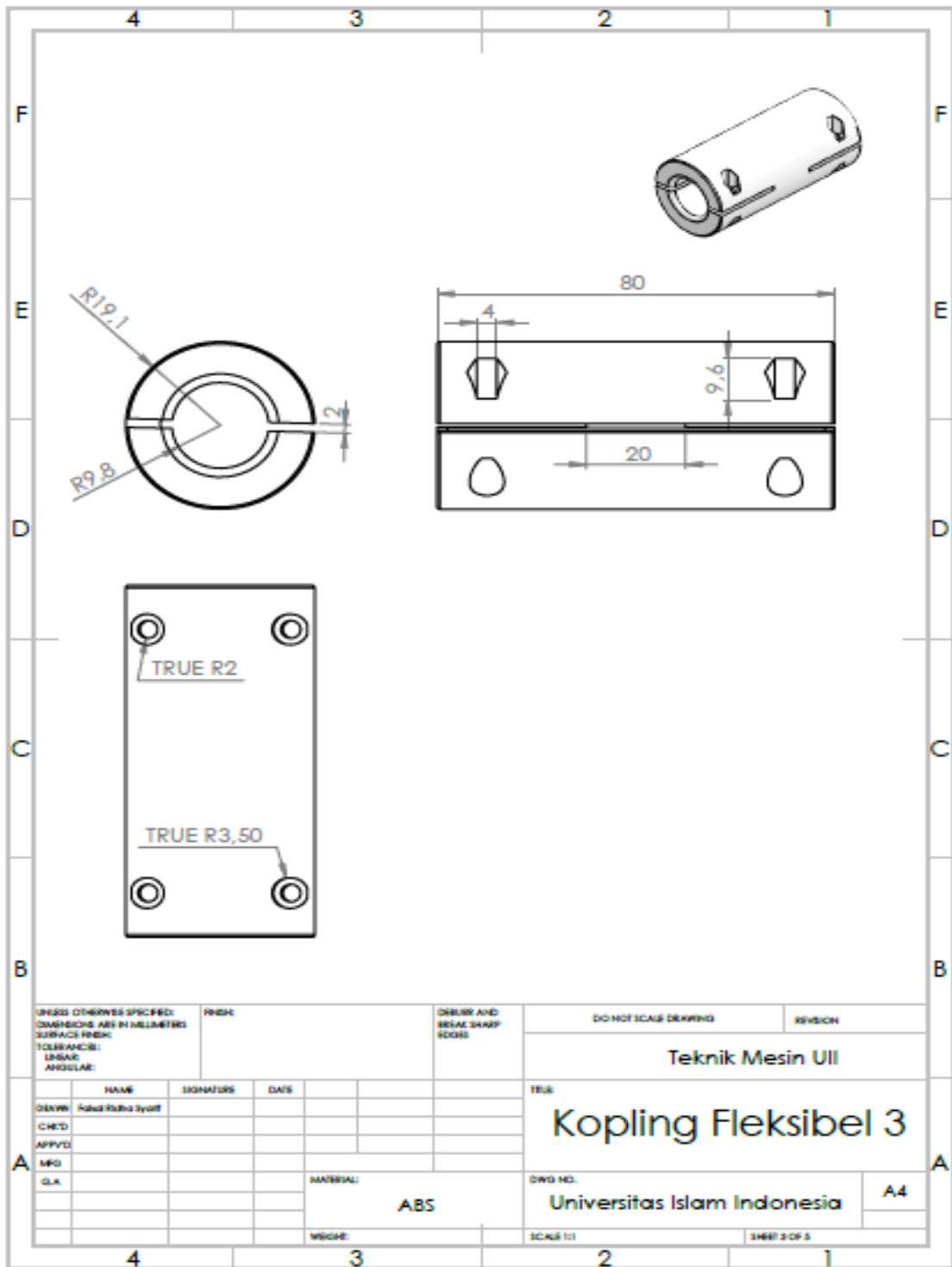

UNLESS OTHERWISE SPECIFIED: DIMENSIONS ARE IN MILLIMETERS SURFACE FINISH: TOLERANCES: UNLESS ANGULAR:		FINISH:	DEBUR AND BREAK SHARP EDGES:	DO NOT SCALE DRAWING	REVISION
				Teknik Mesin UII	
DRAWN: <u>Rahul Raha Syarif</u>				TITLE:	
CHECKED:				Kopling Fleksibel 3	
APPROVED:				DWG NO. Universitas Islam Indonesia	
MFG:				A4	
QA:				SCALE 1:1	
MATERIAL: ABS				SHEET 2 OF 2	
WEIGHT:					

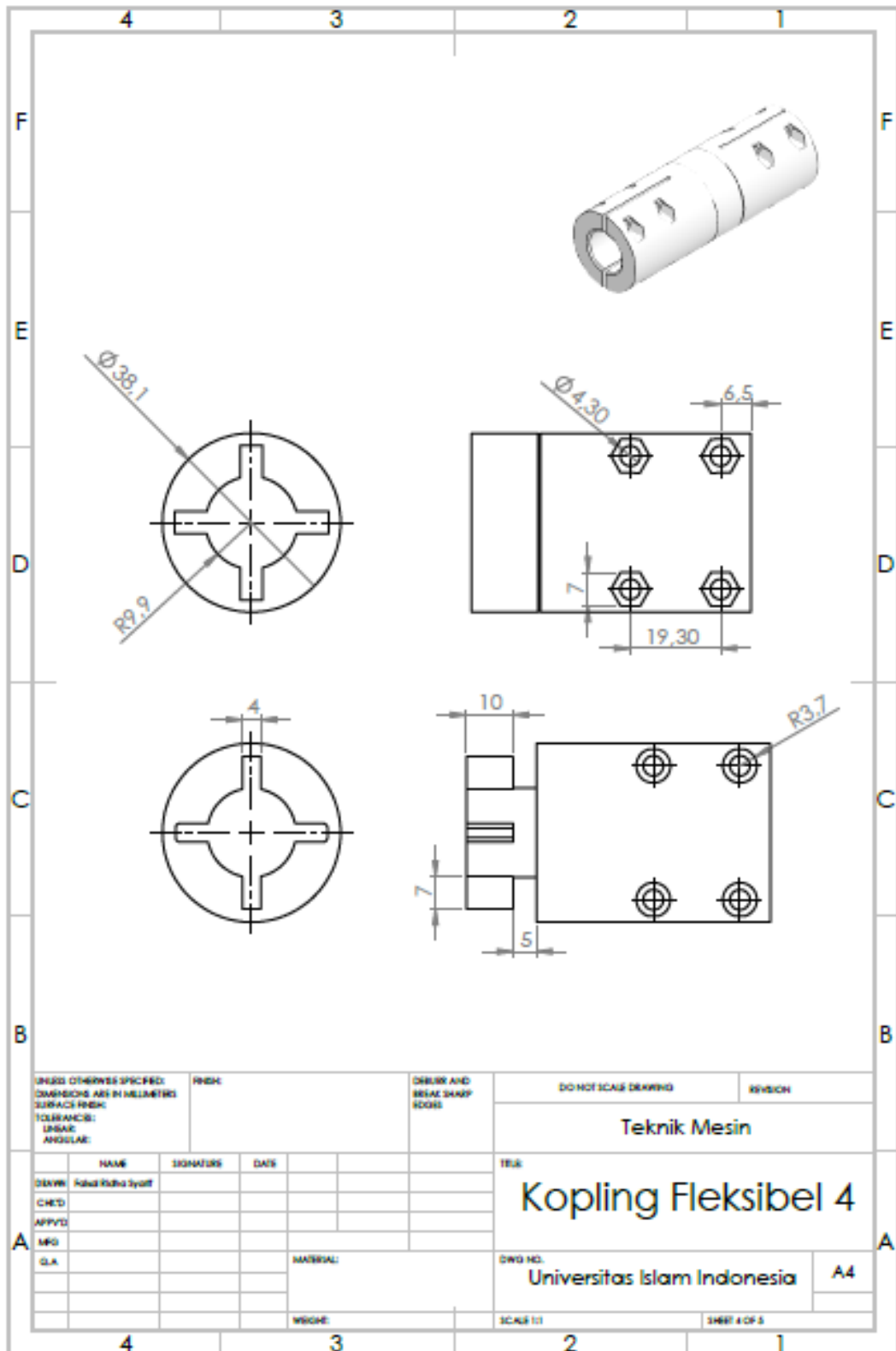

UNLESS OTHERWISE SPECIFIED: DIMENSIONS ARE IN MILLIMETERS SURFACE FINISH TOLERANCES: LINEAR ANGULAR		FINISH	DRESS AND BREAK SHARP EDGES		DO NOT SCALE DRAWING	REVISION
					Teknik Mesin	
					TITIK	
					Kopling Fleksibel 4	
					DWG NO.	
					Universitas Islam Indonesia	
					A4	
					SCALE 1:1	
					SHEET 4 OF 5	

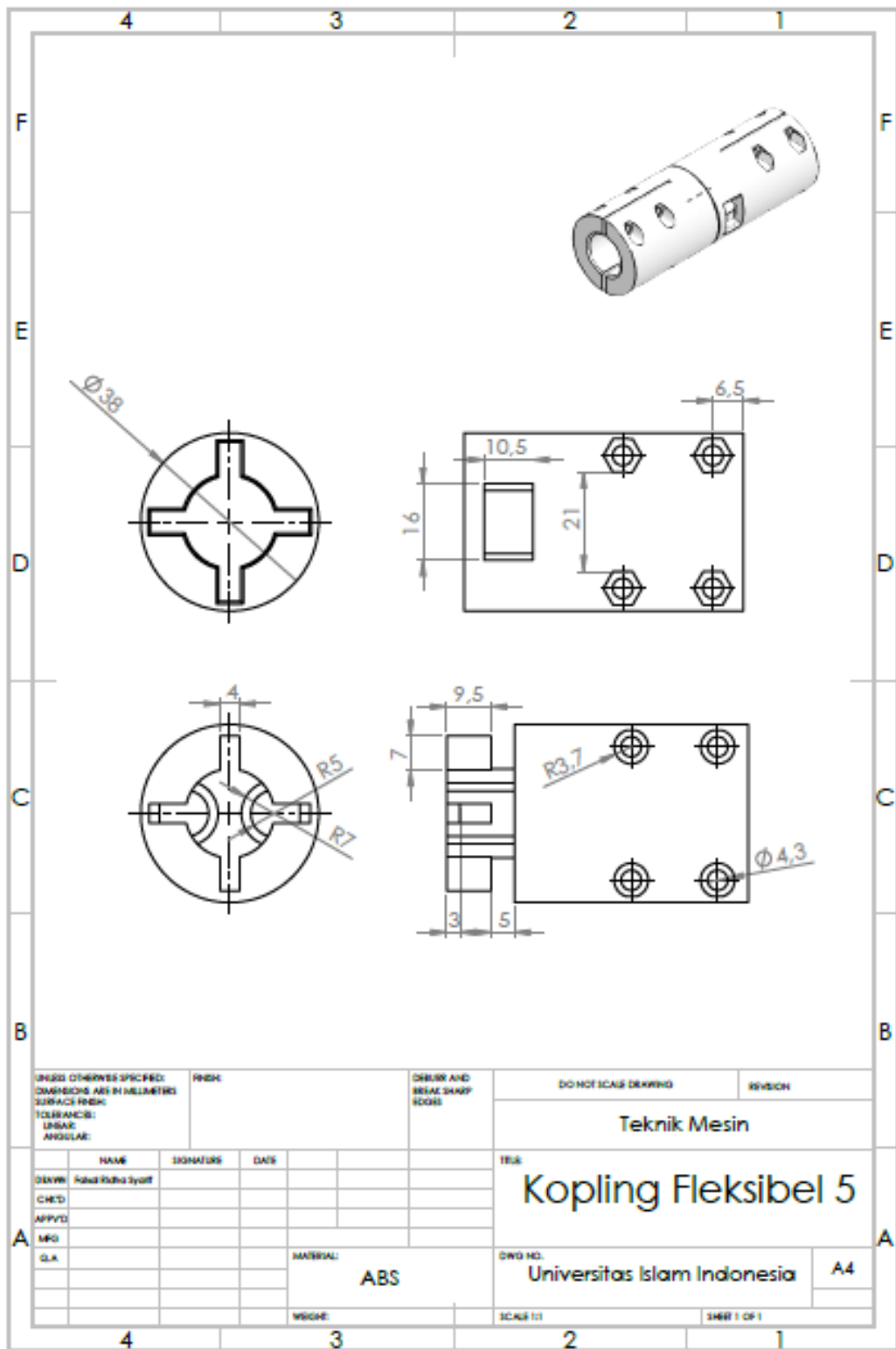

Displacment (Uji Tarik) dengan gaya 20 Kg

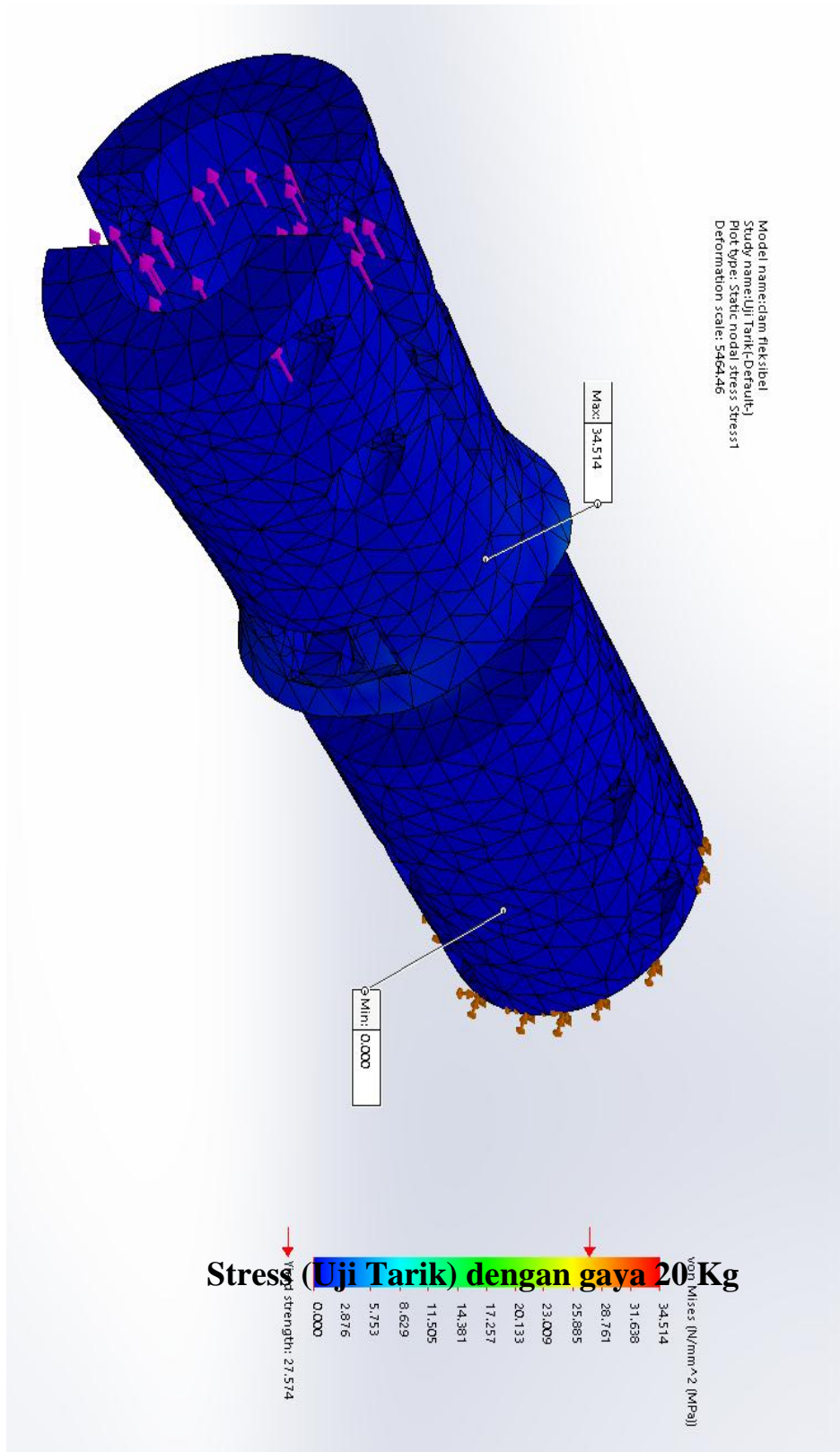

Stress (Uji Tarik) dengan gaya 20 Kg

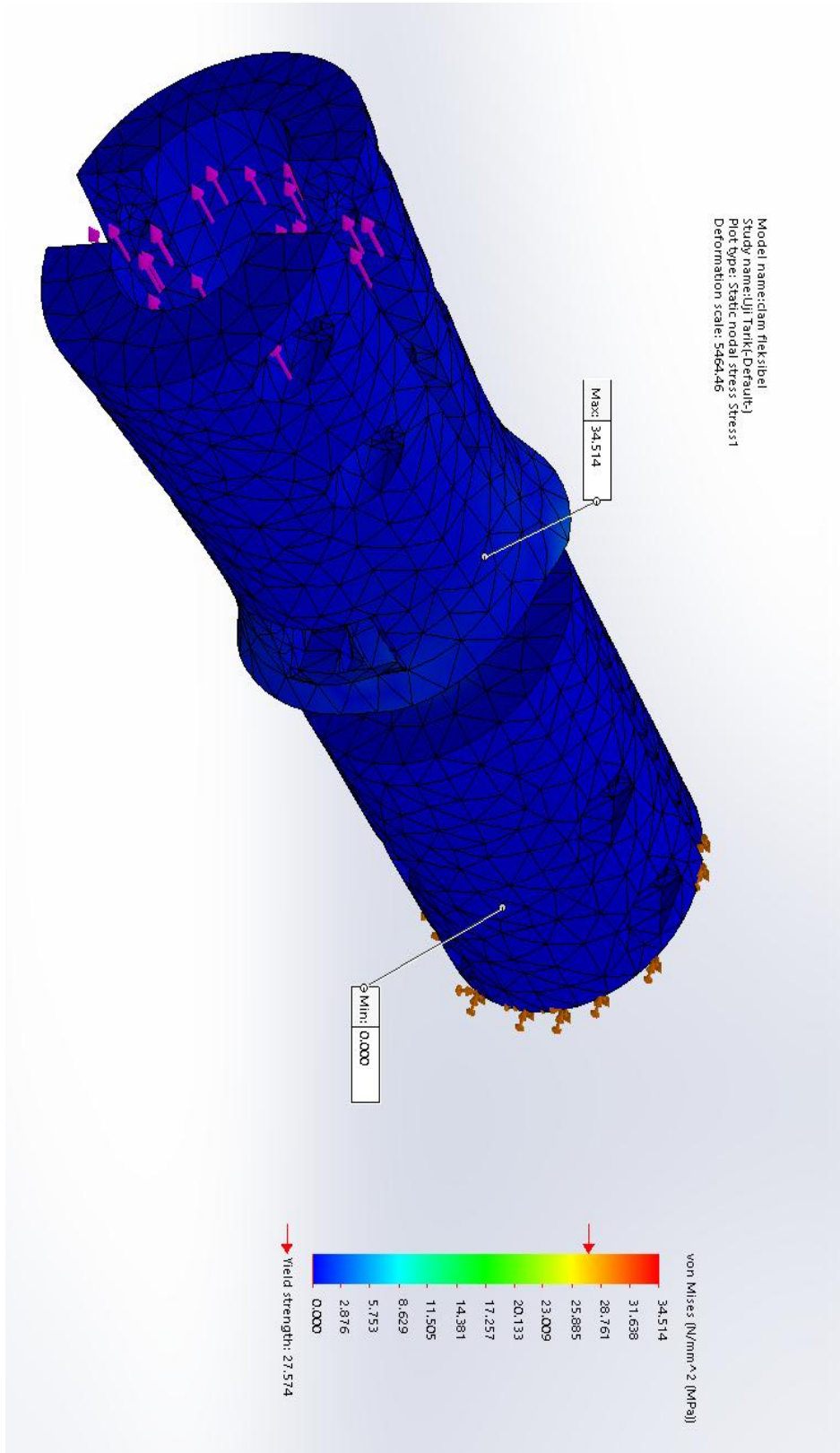

Displacment (Uji Torsi) dengan gaya 20 Kg

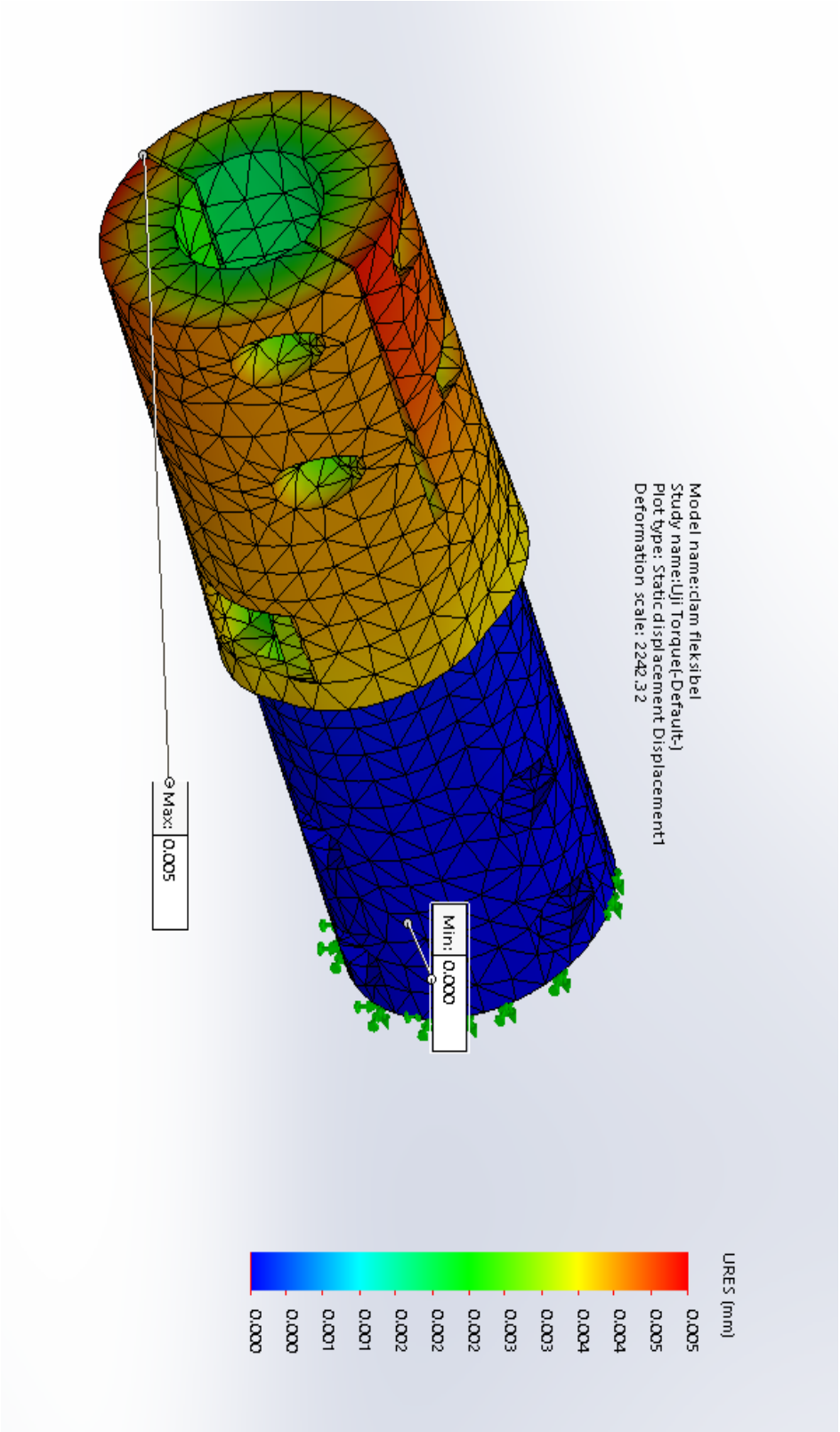

Stress (Uji Torsi) dengan gaya 20 Kg

