



## PENGERTIAN JUDUL

# “ STOP FUN-CENTER ” IN PALEMBANG

- STOP
- FUN
- CENTER

: “ BERHENTI SESAAT ” ~ SIMBOLIS  
Harus tegas

: \* Kegiatan santai, melepas lelah  
\* Senang – senang, enjoy  
\* Menyenangkan, usir rasa jenuh  
\* Bebas “ berekspresi ”

: Pusat kegiatan ~~~~~ ‘INTI’  
Pokok pangkal atau tempat yang menjadi pempunan  
berbagai urusan kegiatan, hal, dan lain: - lain

Suatu wadah yang mewadahi  
outdoor maupun indoor di waktu sengang bagi masyarakat kota Palembang.

baik

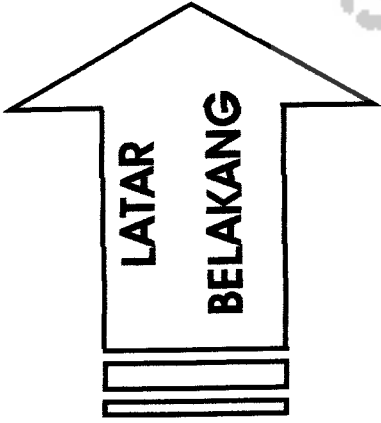

**LATAR**

**BELAKANG**

KEJENUHAN RUTINITAS  
KEGIATAN KESEHARIAN. . . . .

KESIBUKAN  
BEKERJA, BELAJAR, DLL

KEINGINAN :

- KUMPUL BARENG KERABAT, TEMAN
- OLAHRAGA
- BELANJA, CUCI MATA
- SANTAI, ENJOY
- JALAN - JALAN

- CAPAI, LELAH
- MALAS
- TIDAK SEMPAT OLAHRAGA
- WAKTU SENGANG SEDIKIT
- KURANG HIBURAN

**BAGAIMANA MENCIPTAKAN TATA RUANG DAN FASADE BANGUNAN**

**YANG MEMBERI KESAN REKREATIF DENGAN TAMPILAN BANGUNAN  
EKSPLOKASI BENTUK TRANSFORMASI DARI JEMBATAN ' AMPERA '**



**PENGUNJUNG :**

- SEGALA UMUR
- PRIA, WANITA
- PELAJAR
- IBU RUMAH TANGGA
- PEKERJA
- KELAS MENENGAH

**KHUSUS**

**PENGELOLA :**

- \* MANAGER
- \* BENDAHARA, SEKRETARIS

**OPERASIONAL :**

- \* KARYAWAN DIVISI FOOD COURTS
- \* KARYAWAN DIVISI BOOK'S STORE
- \* KARYAWAN DIVISI SHOOP'S COUNTER
- \* KARYAWAN DIVISI SARANA OLAHRAGA

\* CLEANING SERVICE

\* KARYAWAN ME

\* SATPAM DAN TUKANG PARKIR

# ORGANISASI RUANG

## STOP FUNCTION CENTER

MGE '06

### W. PEMUNGUNG

#### \* DEWASA

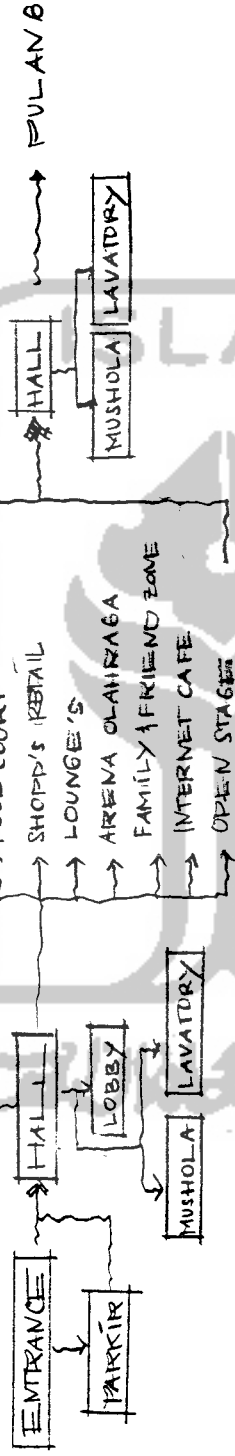

#### \* REMAJA

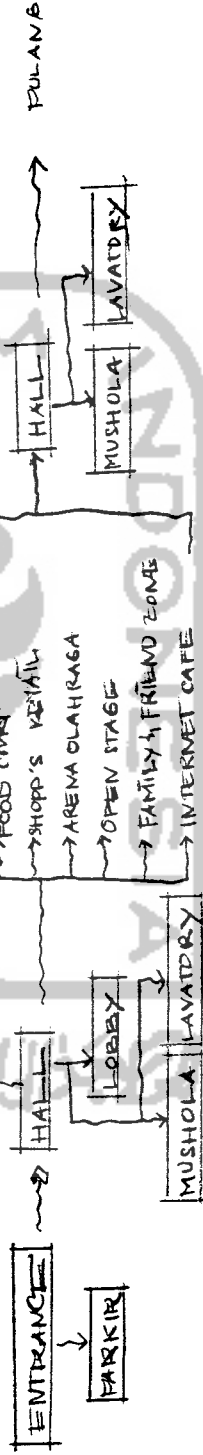

# ORGANISASI

## RUANG

303  
KORIDOR

\* AVAK - AVAK

W/10 PEMBELAJARAN

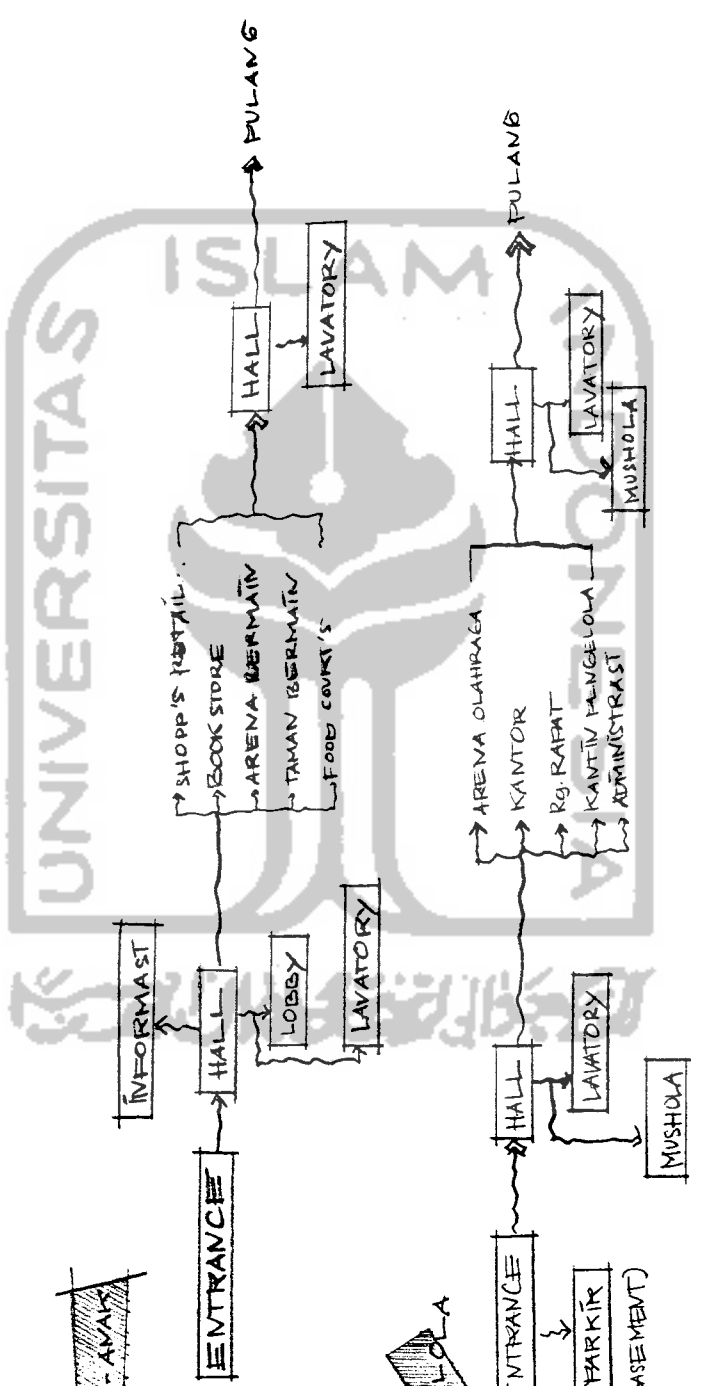

# ORGANISASI ERUANG

PAGE THREE

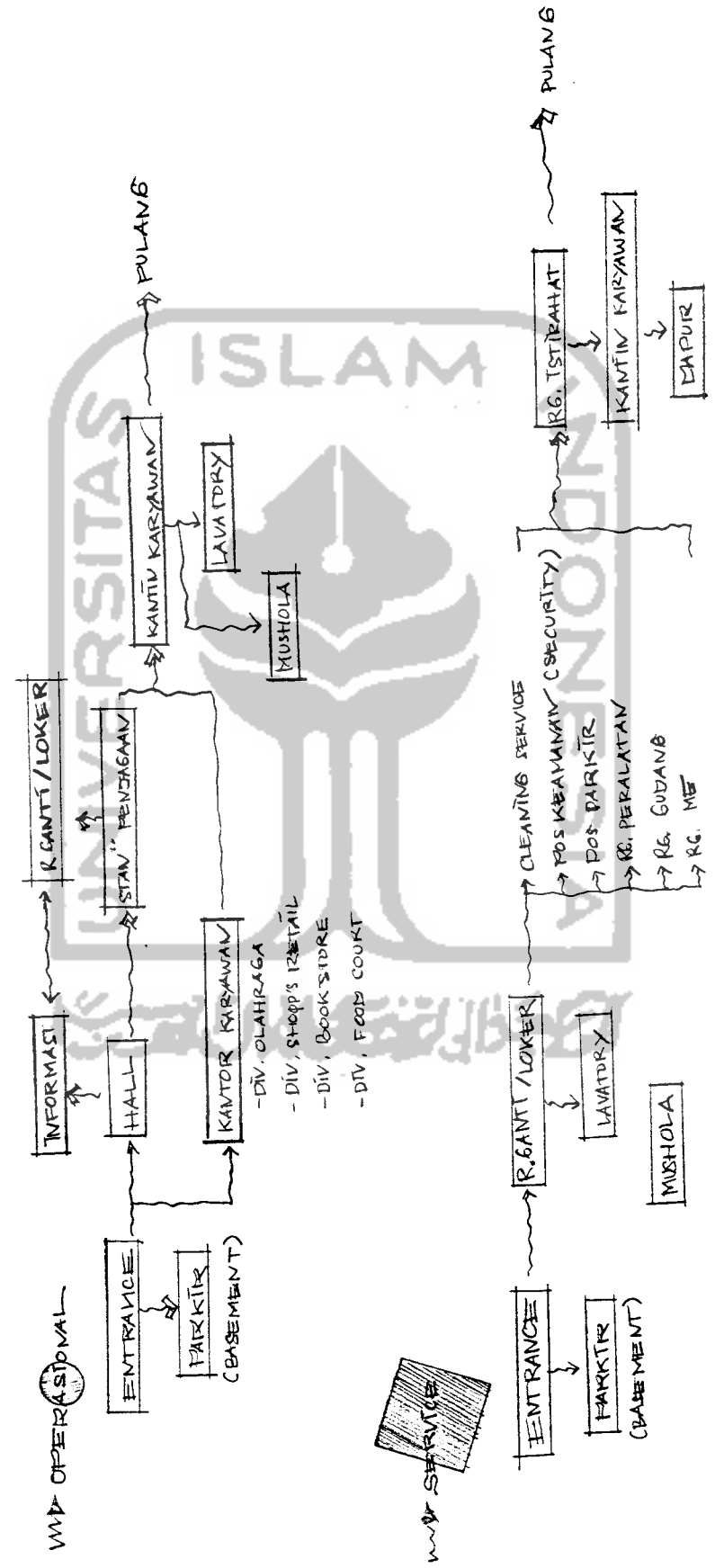

# BESARAN RUANG

PAGE "ONE"

## KELOMPOK PENGELOLA

ELEMENT RUANG	SIFAT	KAPASITAS	UNIT	STANDARD	TOTAL
* Rg GENERAL MANAGER	PRIVATE	1 ORG	1	25 M <sup>2</sup> /ORG	25 M <sup>2</sup>
* Rg. MANAGER PEMASARAN	PRIVATE	1 ORG	1	25 M <sup>2</sup> /ORG	25 M <sup>2</sup>
* Rg. MANAGER KEU+ ADM	PRIVATE	1 ORG	1	25 M <sup>2</sup> /ORG	25 M <sup>2</sup>
* Rg BENDAHARA SEKRETARIS	PRIVATE	4 ORG	1	5 M <sup>2</sup> /ORG	20 M <sup>2</sup>
* Rg. MANAGER PEMELIHARAAN	PRIVATE	1 ORG	1	25 M <sup>2</sup> /ORG	25 M <sup>2</sup>
* Rg RAPAT	PUBLIC	10 ORG	1	0,8 M <sup>2</sup> /ORG	10 M <sup>2</sup>
* LAVATORY	PRIVATE	25 ORG	1	0,8 M <sup>2</sup> /ORG	20 M <sup>2</sup>
		2 ORG	2	1,5 M <sup>2</sup> /ORG	6 M <sup>2</sup>
				JUMLAH	156 M <sup>2</sup>

TOTAL LUAS AREA  
(+ 30% SIRKULASI)

= 202,8 M<sup>2</sup>

## KELOMPOK OPERASIONAL

ELEMENT RUANG	SIFAT	KAPASITAS	UNIT	STANDARD	TOTAL
* Rg DIVISI FOOD COURT (CAFETERIA)	S. PUBLIC	20 ORG	1	1,5 M <sup>2</sup> /ORG	30 M <sup>2</sup>
* Rg. DIVISI BOOKSTORE (MPP)	S. PUBLIC	20 ORG	1	1,5 M <sup>2</sup> /ORG	30 M <sup>2</sup>
* Rg. DIVISI SHOPPING (KARY)	S. PUBLIC	50 ORG	1	1,5 M <sup>2</sup> /ORG	75 M <sup>2</sup>
* Rg. DIVISI CLATHRAGA	S. PUBLIC	15 ORG	1	1,5 M <sup>2</sup> /ORG	22,5 M <sup>2</sup>
* LAVATORY	PRIVATE	6 ORG	3	1,5 M <sup>2</sup> /ORG	27 M <sup>2</sup>
				JUMLAH	130 M <sup>2</sup>

TOTAL LUAS AREA  
(+ 30% SIRKULASI) = 169 M<sup>2</sup>



KELOMPOK FASILITAS UTAMA (INDOOR)

ELEMEN RUANG	SIFAT	KAPASITAS	UNIT	STANDAR	TOTAL
* LOBBY	PUBLIC	10 ORG	2	0,8 M <sup>2</sup> /ORG	16 M <sup>2</sup>
* HALL	PUBLIC	300 ORG	1	0,6 M <sup>2</sup> /ORG	180 M <sup>2</sup>
* FOOD COURTS (INDOOR)	PUBLIC	100 ORG	2	0,8 M <sup>2</sup> /ORG	160 M <sup>2</sup>
* LOUNGE'S	S. PRIVATE	50 ORG	1	0,8 M <sup>2</sup> /ORG	40 M <sup>2</sup>
* FAMILY FRIENDS ZONE	S. PUBLIC	50 ORG	1	0,8 M <sup>2</sup> /ORG	40 M <sup>2</sup>
* BOOK STORE	PUBLIC		1	100 M <sup>2</sup>	100 M <sup>2</sup>
* SHOPP'S RETAIL	PUBLIC	6	10	20 M <sup>2</sup>	200 M <sup>2</sup>
* LAVATORY	PRIVATE	20 ORG	6	1,5 M <sup>2</sup> /ORG	90 M <sup>2</sup>
* INTERNET CAFE	S. PUBLIC	20 ORG	1	1 M <sup>2</sup> /ORG	20 M <sup>2</sup>
* CAFE BAR	PUBLIC		1	5 M <sup>2</sup>	5 M <sup>2</sup>
* SQUASH ARENA - R6, TUNGGU	PUBLIC	2 ORG	3	100 M <sup>2</sup>	300 M <sup>2</sup>
* BOWLING ARENA R6 TUNGGU	PUBLIC	10 LINE	1	0,8 M <sup>2</sup> /ORG	8 M <sup>2</sup>
* ARENA BERMANN	PUBLIC	50 ANAK	1	1 M <sup>2</sup> /ORG	50 M <sup>2</sup>
				TOTAL	1413 M <sup>2</sup>

LUAS TOTAL AREA (+20% SIRKULASI) = 1836,9 M<sup>2</sup>

KELOMPOK FASILITAS UTAMA (OUTDOOR)

ELEMEN RUANG	SIFAT	KAPASITAS	UNIT	STANDAR	TOTAL
* OPEN STAGE	PUBLIC	200 ORG	1	0,8 M <sup>2</sup>	160 M <sup>2</sup>
* BASKETBALL ARENA	PUBLIC		1	128 M <sup>2</sup>	128 M <sup>2</sup>
* FOOD COURT	PUBLIC	100 ORG	1	0,8 M <sup>2</sup> /ORG	80 M <sup>2</sup>
* LAVATORY	PRIVATE	4 ORG	2	1,5 M <sup>2</sup> /ORG	12 M <sup>2</sup>
* TAMAN BERMAIN	PUBLIC	50 ORG	1	1 M <sup>2</sup> /ORG	50 M <sup>2</sup>
				TOTAL	430 M <sup>2</sup>

TOTAL LUAS AREA (+20% SIRKULASI) = 559 M<sup>2</sup>



**MELOMPOK FASILITAS PENDUKUNG (SERVICE)**

ELEMEN RUANG	SIFAT	KAPASITAS	UNIT	STANDARD	TOTAL
* GUDANG	S. PRIVATE		1	20 M <sup>2</sup>	20 M <sup>2</sup>
* R. GEMING SERVICE	S. SERVICE		1	15 M <sup>2</sup>	15 M <sup>2</sup>
* R. GENSET	S. PUBLIC		1	25 M <sup>2</sup>	25 M <sup>2</sup>
* R. AHU	S. PUBLIC		1	12 M <sup>2</sup>	12 M <sup>2</sup>
* R. MECHANICAL	-		1	25 M <sup>2</sup>	25 M <sup>2</sup>
* R. PANEL KONTROL	-		1	25 M <sup>2</sup>	25 M <sup>2</sup>
* R. TREATMENT	-		1	25 M <sup>2</sup>	25 M <sup>2</sup>
* R. PUMPIING WATER	-		1	20 M <sup>2</sup>	20 M <sup>2</sup>
* R. SAMPAH	S. SERVICE	4	1	5 M <sup>2</sup>	5 M <sup>2</sup>
* LAVATORY	PRIVATE	30 ORG	1	15 M <sup>2</sup> /ORG	6 M <sup>2</sup>
* DAPUR + KANTIN	DAPUR	30 ORG	1	1 M <sup>2</sup> /ORG	30 M <sup>2</sup>
TOTAL					208 M <sup>2</sup>

TOTAL LUAS AREA (+30% SIRKULASI) 270,4 M<sup>2</sup>

* POS SATPAM	S. PUBLIC	2 ORG	1	1 M <sup>2</sup> /ORG	4 M <sup>2</sup>
* POS PARKIR	S. PUBLIC	2 ORG	2	0,8 M <sup>2</sup> /ORG	3,2 M <sup>2</sup>
* PARKIR PENGELOLA					
* KARYAWAN	PUBLIC	20	1	15 M <sup>2</sup>	300 M <sup>2</sup>
* MOBIL	PUBLIC	50	1	0,8 M <sup>2</sup>	40 M <sup>2</sup>
* MOTOR	PUBLIC	50	1	15 M <sup>2</sup>	750 M <sup>2</sup>
* P. PENGUNJUNG	PUBLIC	80	1	1 M <sup>2</sup>	80 M <sup>2</sup>
* MOBIL					
* MOTOR					

11,2 M<sup>2</sup> x 30% = 14,56 M<sup>2</sup>

18,20 M<sup>2</sup> x 50% = 19,45 M<sup>2</sup>

**10 LANTAI SATU**

*												
*	LOBBY	PUBLIC	1	10 ORG	130%	2	0,8 M <sup>2</sup> /ORG	20,8 M <sup>2</sup>				
*	HALL	PUBLIC	1	300 ORG	30%	1	0,6 M <sup>2</sup> /ORG	23,4 M <sup>2</sup>				
*	FOOD COURTS	PUBLIC	2	100 ORG	30%	2	0,8 M <sup>2</sup> /ORG	20,8 M <sup>2</sup>				
*	BOOK STORE	PUBLIC	1	6 ORG	30%	1	1,00 M <sup>2</sup>	1,00 M <sup>2</sup>				
*	LAVATORY	PRIVATE	3	2 ORG	30%	3	1,5 M <sup>2</sup> /ORG	35,1 M <sup>2</sup>				
*	SQUASH ARENA	PUBLIC	5	20 ORG	30%	5	1,00 M <sup>2</sup>	15,00 M <sup>2</sup>				
*	RITING SU	PUBLIC	1	20 ORG	30%	1	3,00 M <sup>2</sup>	3,00 M <sup>2</sup>				
*	INTERNET CAFE	PUBLIC	1	100 ORG	30%	1	1 M <sup>2</sup> /ORG	26 M <sup>2</sup>				
*	ARENA BERMAIN	PUBLIC	1	100 ORG	30%	1	1 M <sup>2</sup> /ORG	1,30 M <sup>2</sup>				
*	TAMAN BERMAIN	PUBLIC	1	100 ORG	30%	1	1 M <sup>2</sup> /ORG	1,30 M <sup>2</sup>				
*	BASKET BALL (OPEN STAGE)	PUBLIC	1	100 ORG	30%	1	1,20 M <sup>2</sup>	25,53 M <sup>2</sup>				
*	FOOD COURT (COMPOUND)	PUBLIC	1	100 ORG	30%	1	0,8 M <sup>2</sup> /ORG	1,64 M <sup>2</sup>				
*	PARKIR PENGELOMPOK	PUBLIC	1	50	50%	1	15 M <sup>2</sup>	11,25 M <sup>2</sup>				
*	* MOBIL	PUBLIC	1	0,5	50%	1	1 M <sup>2</sup>	27,5 M <sup>2</sup>				
*	* MOTOR	PUBLIC	1	2 ORG	30%	1	1 M <sup>2</sup> /ORG	10 M <sup>2</sup>				
*	POS SATPAM	PUBLIC	1	2 ORG	30%	1	0,8 M <sup>2</sup> /ORG	4,16 M <sup>2</sup>				
*	POS PARKIR	PUBLIC	1	2 ORG	30%	1	0,8 M <sup>2</sup> /ORG	156 M <sup>2</sup>				
*	OPEN SPACE (IMP DUKUR 20)	PUBLIC	1	200 ORG	30%	1	0,6 M <sup>2</sup> /ORG					
TOTAL 3487,26 M <sup>2</sup>												

PERHITUNGAN RC =

RC = LUAS LANTAI 1 x 100%

LUAS LANTAI = 3487,26 x 100%

15.000

= 23,25%

# BESARAN RUANG

## KELOMPOK PENGELOLA

	ELEMEN RUANG	SIFAT	KAPASITAS	UNIT	STANDARD	TOTAL
1	R. General Manager	private	1 org	1	25m <sup>2</sup> /org	25m <sup>2</sup>
2	R. Manager Divisi	private	3 org	1	25m <sup>2</sup> /org	25m <sup>2</sup>
3	R. Bend& sekretaris	private	4 org	1	5m <sup>2</sup> /org	20m <sup>2</sup>
4	R. Rapat kecil	public	10 org	1	1,2m <sup>2</sup> /org	12m <sup>2</sup>
5	R. Rapat besar	Public	30 org	1	1,2m <sup>2</sup> /org	36m <sup>2</sup>
6	Lavatory	private	1org	3	2,5m <sup>2</sup>	7,5m <sup>2</sup>
	<b>TOTAL</b>					125,5 m <sup>2</sup>

TOTAL = 125,5m<sup>2</sup> + sirkulasi 30%  
= 163,15m<sup>2</sup>

## KELOMPOK OPERASIONAL

	ELEMEN RUANG	SIFAT	KAPASITAS	UNIT	STANDARD	TOTAL
1	R. Divisi - Divisi	semi public	10 org	1	30m <sup>2</sup>	30m <sup>2</sup>
2	R. Lavatory	private	1 org	3	2,5m <sup>2</sup>	7,5m <sup>2</sup>

<b>TOTAL</b>	<b>37,5m<sup>2</sup></b>
--------------	--------------------------

TOTAL = 37,5m<sup>2</sup> + sirkulasi 30%  
= 48,5m<sup>2</sup>

**KELOMPOK FASILITAS UTAMA**

	<b>ELEMEN RUANG</b>	<b>SIFAT</b>	<b>KAPASITAS</b>	<b>UNIT</b>	<b>STANDARD</b>	<b>TOTAL</b>
1	Lobby	public	10 org	1	0,8m <sup>2</sup> /org	16m <sup>2</sup>
2	Hall	public	500 org	1	0,6m <sup>2</sup> /org	300m <sup>2</sup>
3	Food's court	public	100 org	4	0,8m <sup>2</sup> /org	320m <sup>2</sup>
4	Retail buku	public	200org	1	150m <sup>2</sup>	150m <sup>2</sup>
5	Shop's retails	public		10	20m <sup>2</sup>	200m <sup>2</sup>
6	Lavatory	private	1org	25	2,5,m <sup>2</sup>	62,5m <sup>2</sup>
7	Lounge's	public	100 org	1	0,8m <sup>2</sup> /org	80m <sup>2</sup>
8	Bar	public		1	10m <sup>2</sup>	10m <sup>2</sup>
9	Internet cafe	public	50 org	1	1m <sup>2</sup> /org	50m <sup>2</sup>
10	Arena bermain anak	public	100 org	1	0,6m <sup>2</sup> /org	60m <sup>2</sup>
11	Squash arena	public	2 org	5	80m <sup>2</sup>	400m <sup>2</sup>
12	Market	public		1	200m <sup>2</sup>	200m <sup>2</sup>
13	R. Tunggu squash arena	public	10 org	1	0,8m <sup>2</sup> /org	8m <sup>2</sup>

14	Bowling arena	public	10 line	1	200m <sup>2</sup> /org	200m <sup>2</sup>
15	R. Tunggu bowling arena	public	50 org	1	0,8m <sup>2</sup> /org	40m <sup>2</sup>
16	R. Transisi	public	200 org	1	0,6m <sup>2</sup> /org	120m <sup>2</sup>
<b>TOTAL</b>						2336,5m <sup>2</sup>

TOTAL = 2336,5m<sup>2</sup> + sirkulasi 30%  
= 3037,75m<sup>2</sup>

#### KELOMPOK FASILITAS PENDUKUNG ( SERVICE )

	ELEMEN RUANG	SIFAT	KAPASITAS	UNIT	STANDARD	TOTAL
1	Gudang	semi private		1	20m <sup>2</sup>	20m <sup>2</sup>
2	R. Cleaning service	private		1	15m <sup>2</sup>	15m <sup>2</sup>
3	R. Genset	private		1	25m <sup>2</sup>	25m <sup>2</sup>
4	R. AHU	private		1	12m <sup>2</sup>	12m <sup>2</sup>
5	R. kantin karyawan + dapur	Public	50 org	1	1m <sup>2</sup> /org	50m <sup>2</sup>
6	R. Treatment	private		1	25m <sup>2</sup>	25m <sup>2</sup>
7	R. shaft sampah	private		1	4m <sup>2</sup>	4m <sup>2</sup>
8	R. Plumbing & water	private		1	25m <sup>2</sup>	25m <sup>2</sup>
9	R. ME & panel kontrol	private		1	25m <sup>2</sup>	25m <sup>2</sup>

10	Mushola	public	20 org	1	0,6m <sup>2</sup> /org	12m <sup>2</sup>
<b>TOTAL</b>						
213 m <sup>2</sup>						

TOTAL = 213m<sup>2</sup> + sirkulasi 30%  
= 276,9m<sup>2</sup>

### KELOMPOK FASILITAS OUTDOOR

	ELEMEN RUANG	SIFAT	KAPASITAS	UNIT	STANDARD	TOTAL
1	Open stage	public	200 org	1	25m <sup>2</sup> /org	25m <sup>2</sup>
2	Pos satpam	private	2 org	2	4m <sup>2</sup>	8m <sup>2</sup>
3	Pos parkir	private	2 org	2	4m <sup>2</sup>	8m <sup>2</sup>
4	Parkir mobil	public	75	1	15m <sup>2</sup>	1687,5m <sup>2</sup>
5	Parkir motor	public	130	1	0,8m <sup>2</sup>	156m <sup>2</sup>
6	Pemancingan	public	40 org	7	5m <sup>2</sup>	35m <sup>2</sup>
7	Taman bermain	public	50 org	1	1m <sup>2</sup> /org	50m <sup>2</sup>
<b>TOTAL</b>						
1355 m <sup>2</sup>						

TOTAL = 1969,5m<sup>2</sup> + sirkulasi 30%  
= 2560,35m<sup>2</sup>

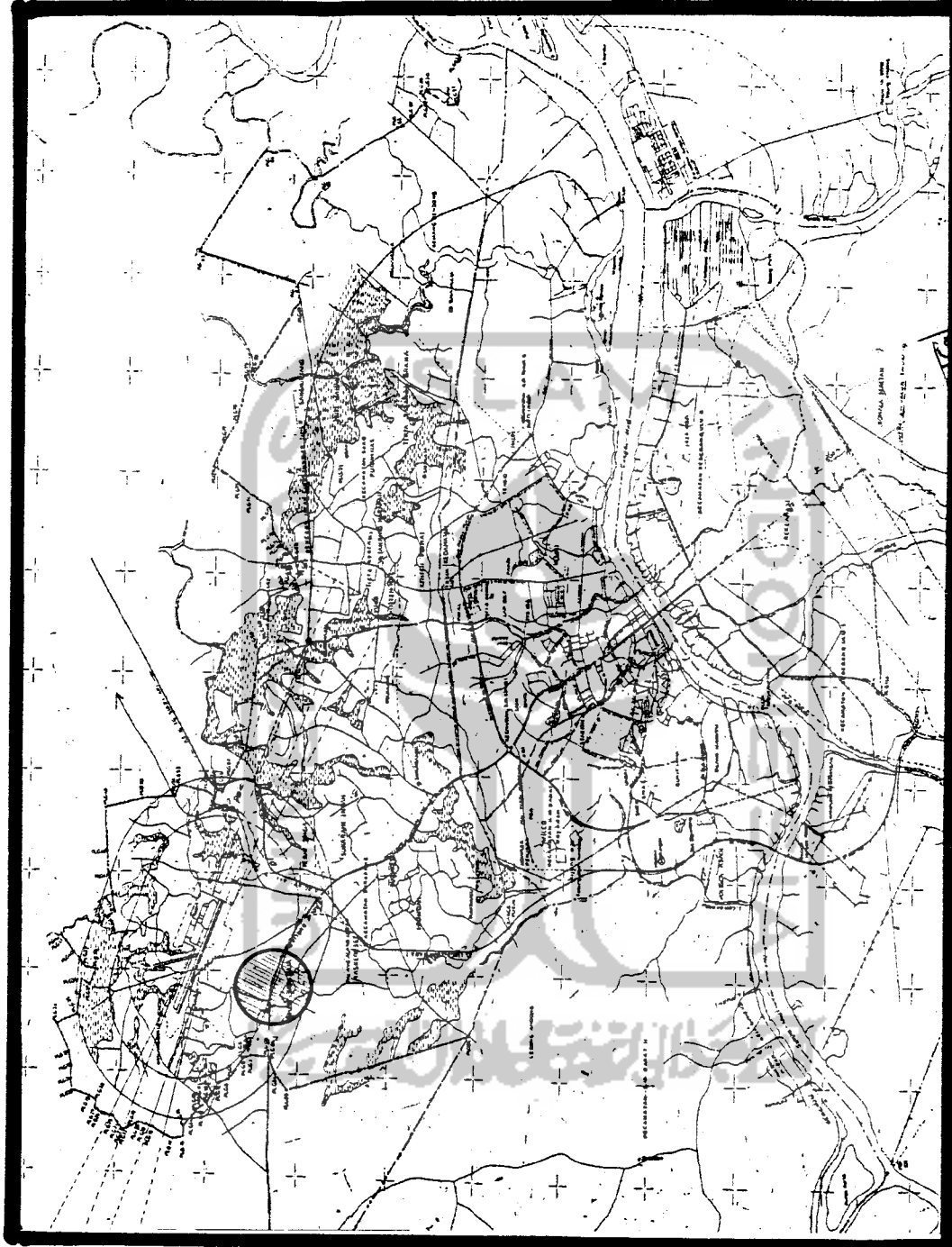

PETA WILAYAH KOTAMADYAN DATI PEMERINTAH  
LOKASITE

KOMPLEK SAGRAMA HASI  
BALAN UTAM

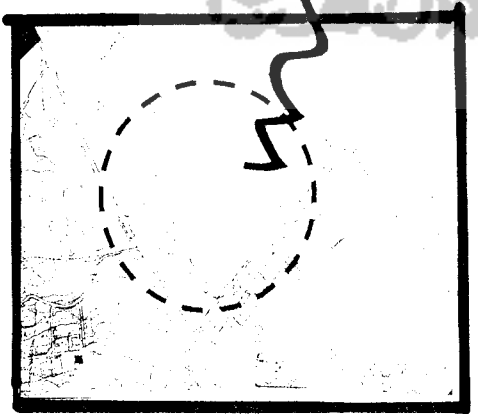
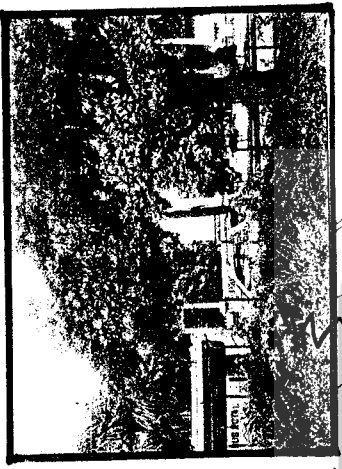

VIEW KELUAR SITE



LAHAN KOSONG  
STOP FUN CENTER

SIAP BANGUN PERUMAHAN  
LAHAN KOSONG



LAHAN SIAP BANGUN  
PERUMAHAN



# ANALISIS TAPAK

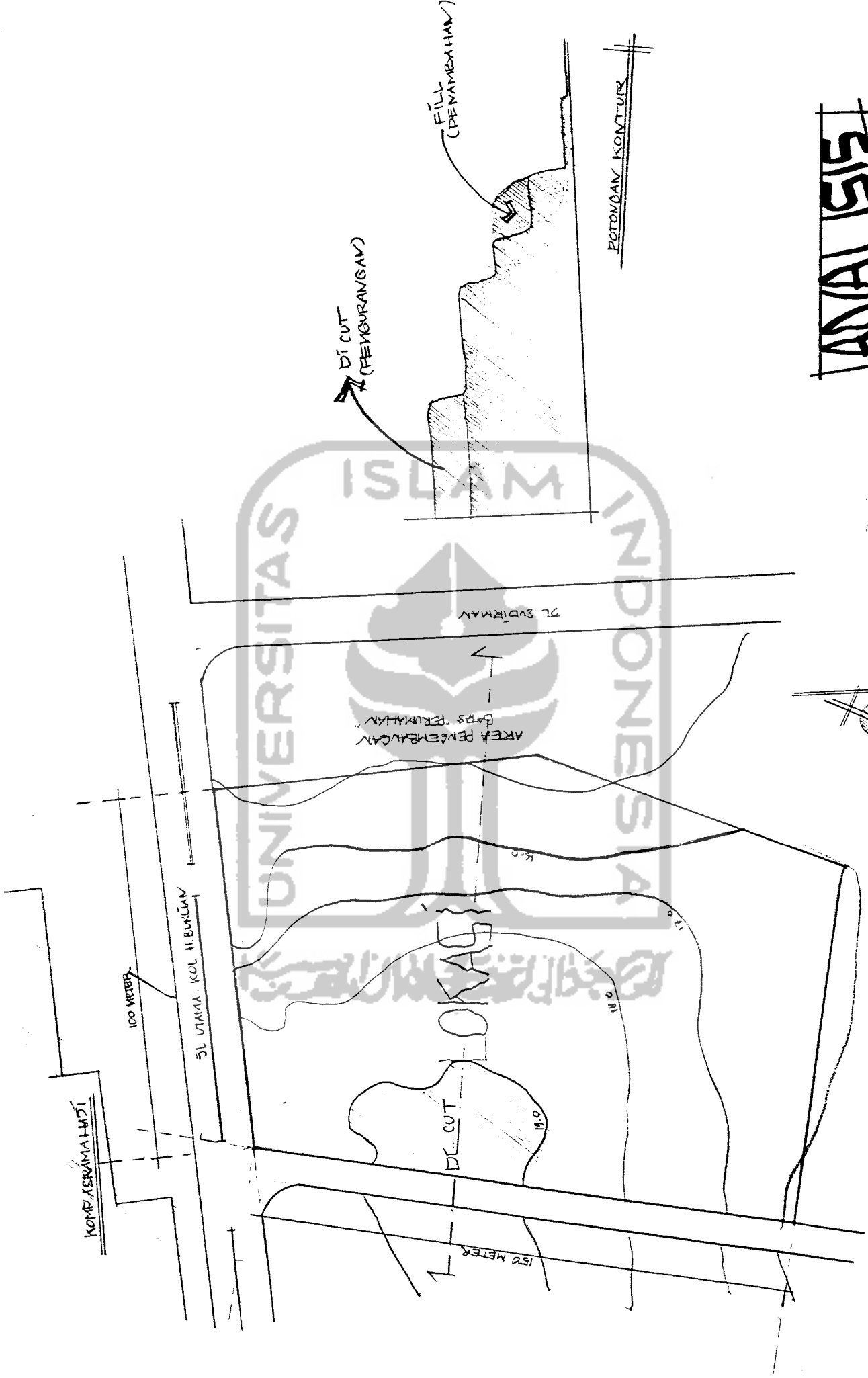

025  
025  
025

UTARA

NOISE / KEBISINGAN  
DAPAT MENGGANGGU AKTIFITAS  
KETERANGAN YG ADA DI DALAM  
BANGUNAN.  
DAPAT DIATASI (DGN ADANYA  
PEMBATAHAN VEGETASI CYG BISA  
DIJADIKAN FILTER) SEKITAR SEBAGAI  
FILTER POLUSI UDARA

TEST MATAHARI

DRAINASE

KETINGGIAN KONTUR  
TUSA DAPAT DIMANFAATI  
KAV UNYUK KETINGGIAN  
BANGUNAN, YANG  
KEMUDIAN MENCIPTAKAN  
BUKAA... YG CUKUP

SEBAGAI "DENGANFANTAI"  
ANGIN "DENGANFANTAI"  
MELALUI ADA PEMANFAATAN  
"KAWAN YANG CUKUP"  
"KAWAN YANG CUKUP"

SELATAN

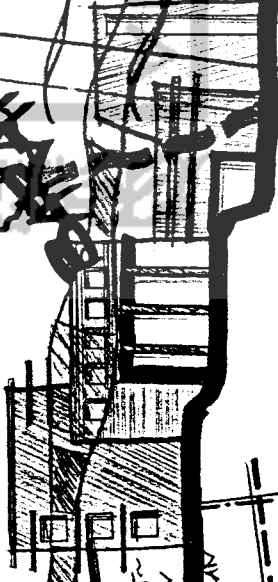
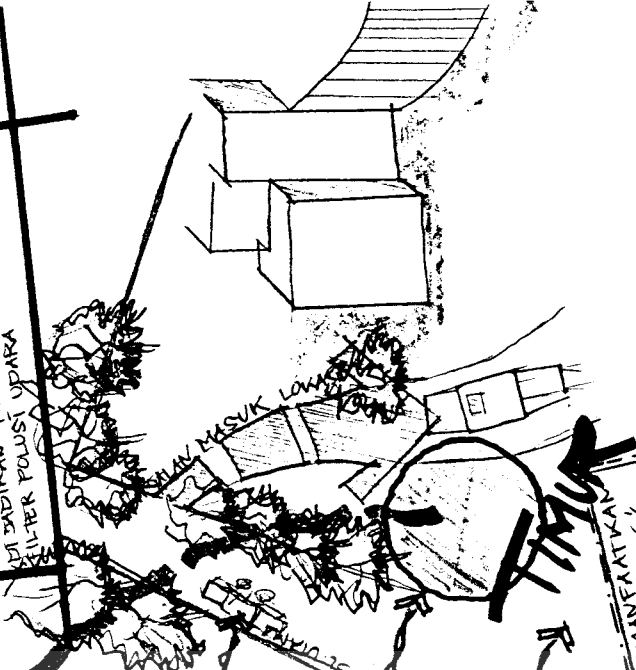

ISLAM



# ZONING

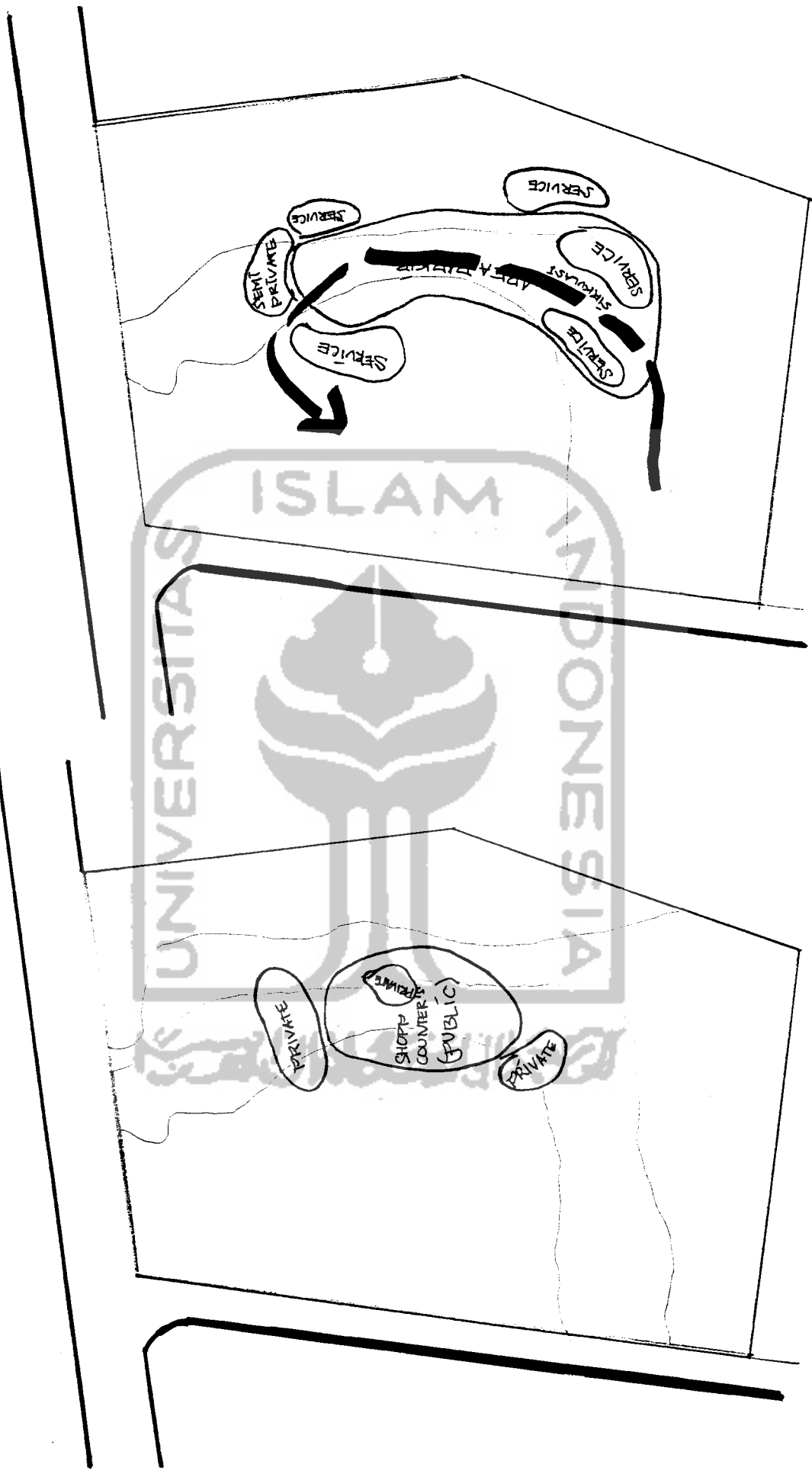

BASMENT

2007  
ELDER

# SIBKULASATI JALAN PENGHUBUNG

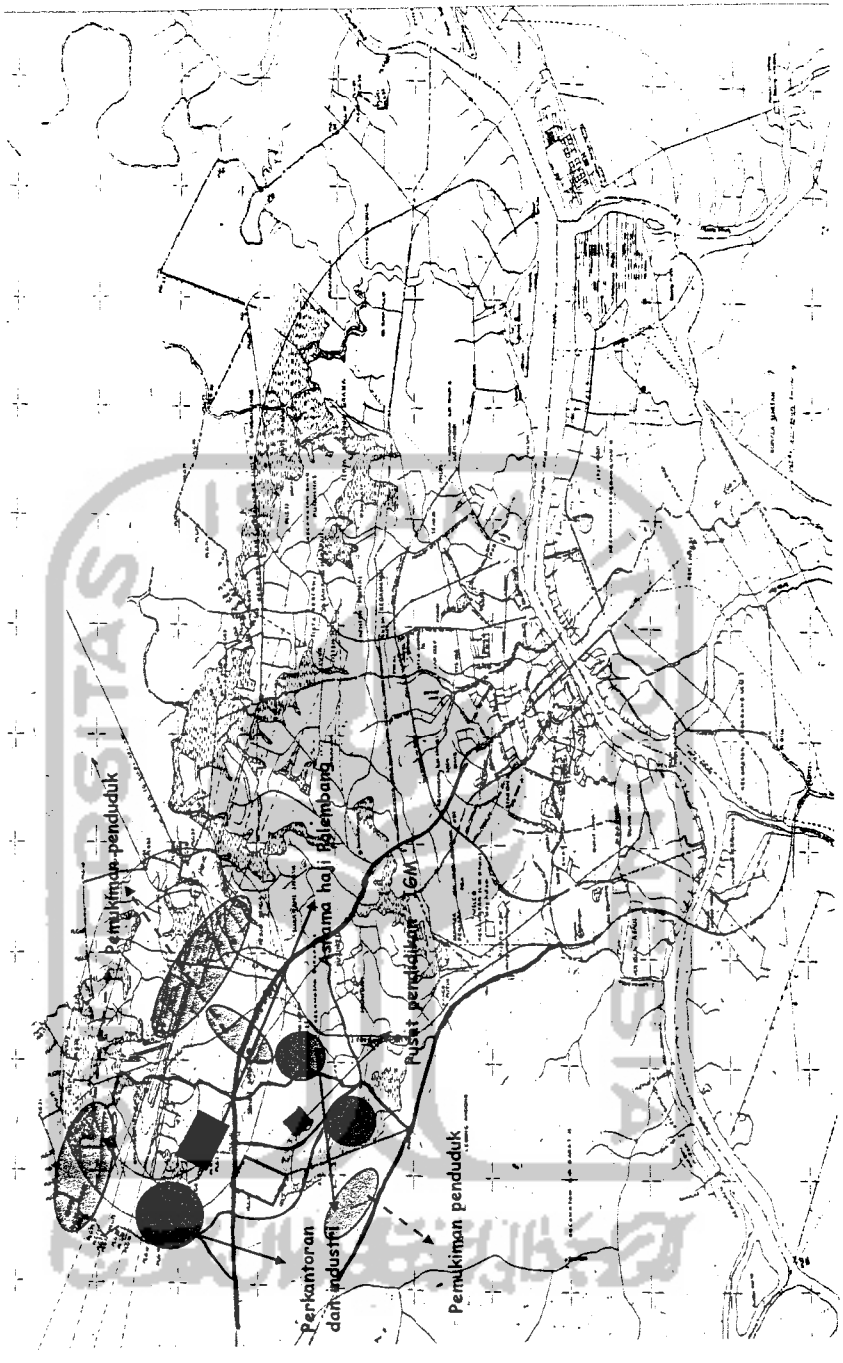

Keterangan garis :

- : Jalan utama / jalan besar
- : Jalan penghubung ( alternatif )
- : Stop Fun Center

# KONSEP BENTUK

## KONJEP → KONTEMPORER

HI-TECH ...

KARAKTERISTIK :

◦ PLURALISME : - TIDAK TERIKAT PADA 1 STYLE

- BANYAK / BERAGAM
- TANPA KESATUAN

◦ EXPLORATIF : → EKSTREM  
STRUKTUR → BERLAWANAN

◦ GEOMETRIK / KEMURNIAN BENTUK  
= - EKSPRESI BEBAS

= - TIDAK ADA PENEKANAN  
STYLE

◦ SIMBOLIS = EKSPRESIONISME FASADE  
\* DI TERIMA SEPANDANG MASA

\* LANDMARK

\* TREND → SEKARANG  
↳ HADATANG

"FUN" → KEGIATAN SANTAI, MELEPAS 'LELAH'

- ▷ SENANG - SEMAN / ENJOY
- ▷ MENYENYANGKAN, USIR RASA JEMUH
- ▷ BEBAS BEREKSPRESI

BANGUNAN "KONTEMPORER"

PERMAINAN "BIDANG"

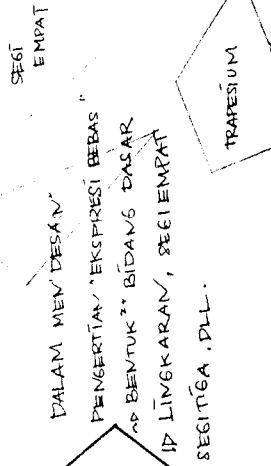

## STOP FUN CENTER



"STOP" →

"BERHENTI SESAT" (SIMBOLIS)

STOP → HARUS TEGAS



JARI-JARI

DALAM DESAIN DIWUJUDKAN DENGAN PERMAINAN "REPETISI" BAIK VERTIKAL MAUPUN HORIZONTAL PADA FASADE BANGUNAN

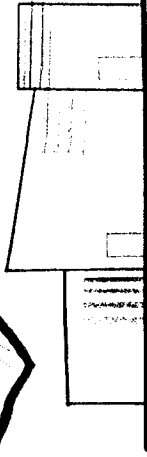
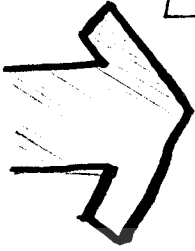

"CENTER" → PUSAT KEGIATAN → INTI

DIPILIH ... → LINGKARAN

→ IDEWIK DENGAN ATAU SEBAGAI PUSAT ATAU POROS.

"LINGKARAN" → SUATU SOSOK YANG TERPUSAT BERARAH KE DALAM } PADA UMUMNYA BERKESIF "STABIL" DAN DGN SENDIRINYA MENJADI PUSAT DR LINGKUNGANNYA. PEMEMPATAN SEBUAH HINGKARAN PADA SUATU BIDANG AKAN M'PERKUAT SIFATNYA SBG POROS (D.K. CHING)

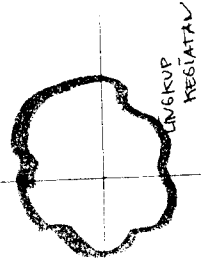

SUBBUK ARSIS

# PEMCAIRAN BENTUK BANGUNAN

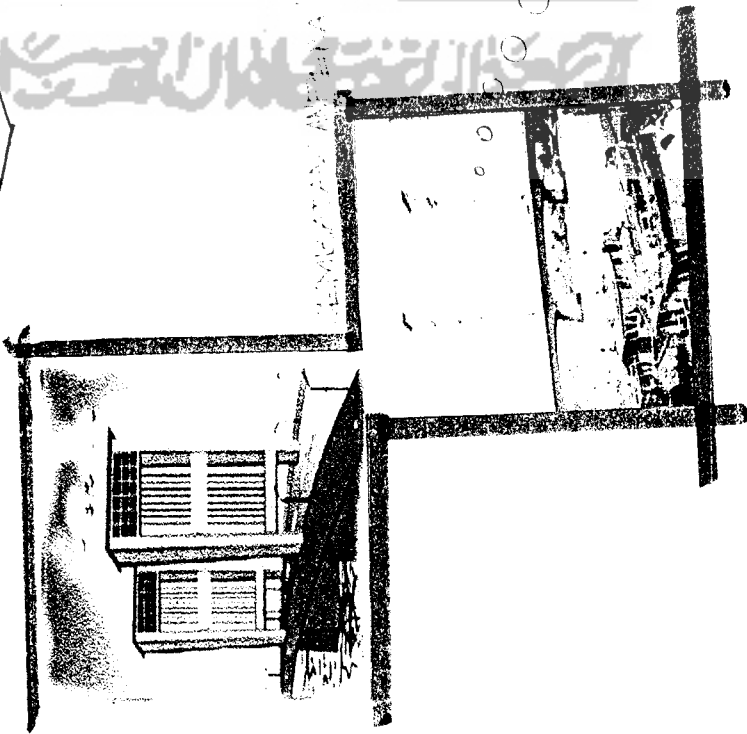

ARSITEKTUR KONTEMPORER  
DALAM "STOP FUN CENTER"

- \* BERAGAM
- \* TANPA KESADAN
- \* EKSPRESI BEBAS
- ↳ PENGOLAHAN BENTUK "FLEKSIBEL"
- \* KONTEKSTUAL DAN CIRI KHAS KOTA PALEMBANG
- \* CENDERUNG ASIMETRIS DEKONSTRUKTIF

BENTUK TRANSISI PADA FASADE BANGUNAN

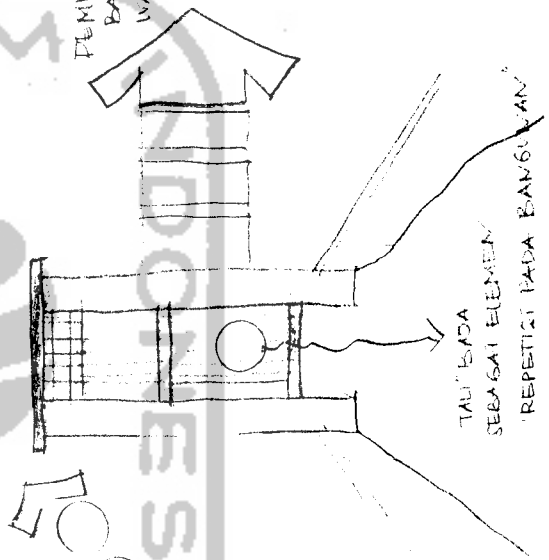

TALI BADA  
SEBAGAI ELEMEN  
REPETISI PADA BANGUNAN

PEMILIHAN WARNA PADA FASADE  
BANGUNAN. DOMINAN MENYESUAIKAN  
WARNA JEMETAN AIRERA

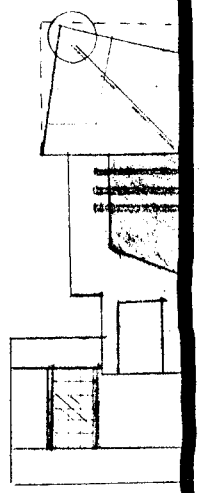

BENTUK MELIBRA PADA  
PERMAINAN MASSA

# PEMULAKIAM BENTUK BANGUNAN

"PART TWO"

JEMBATAN 'AMPERA' SBC SIMBOL PAERAH

- ↳ LIMIER
- ↳ MERAH, KUMING, ABU™.
- ↳ KOLON-KOLON PENOPANG
- ↳ BENTUK SIMBEL NAMUN KOKOH

BENTUK "TRANSFORMASI" PADA BANGUNAN

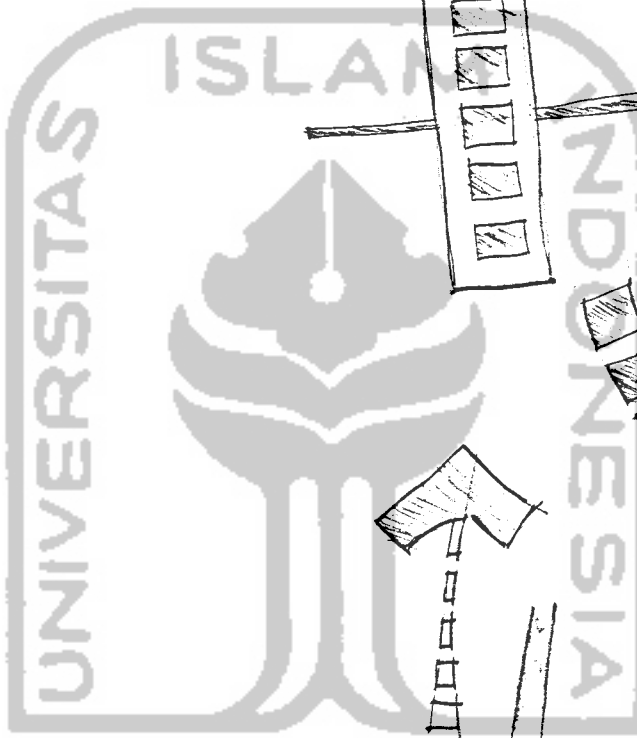
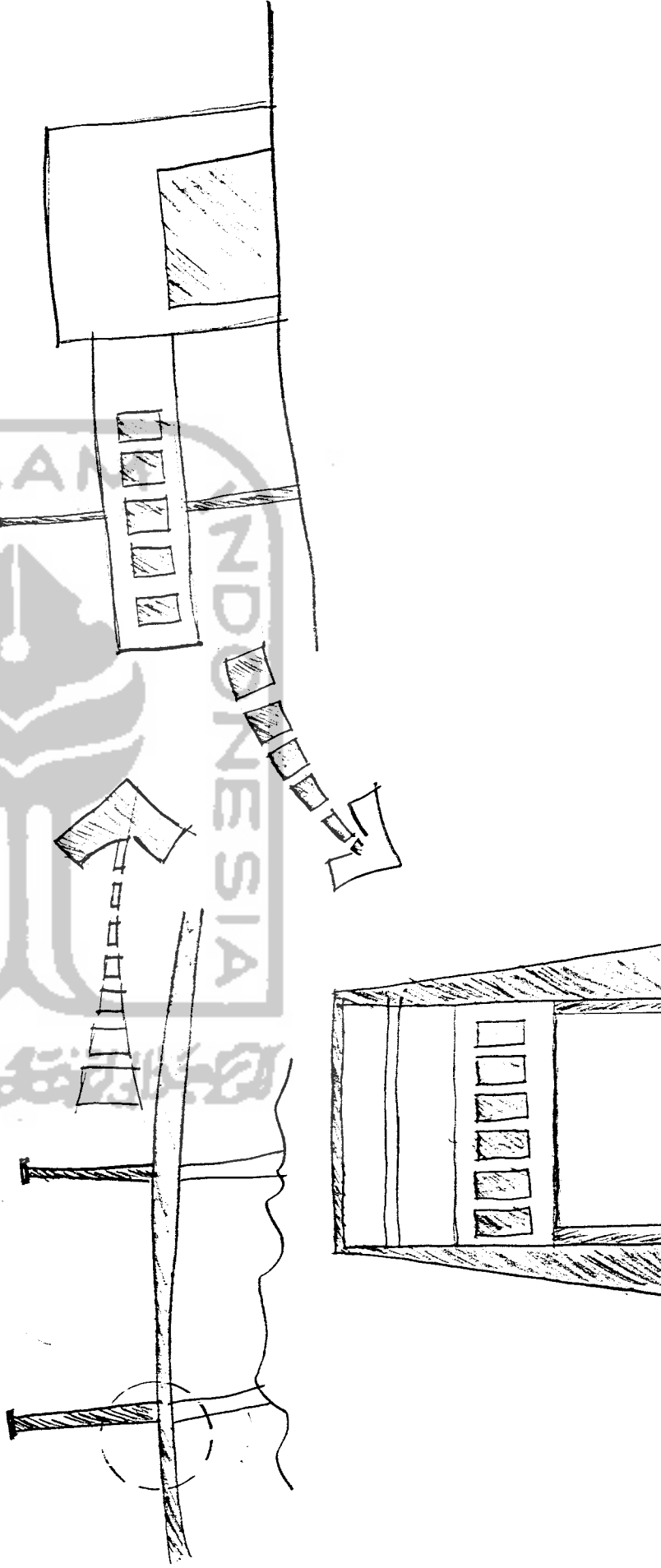



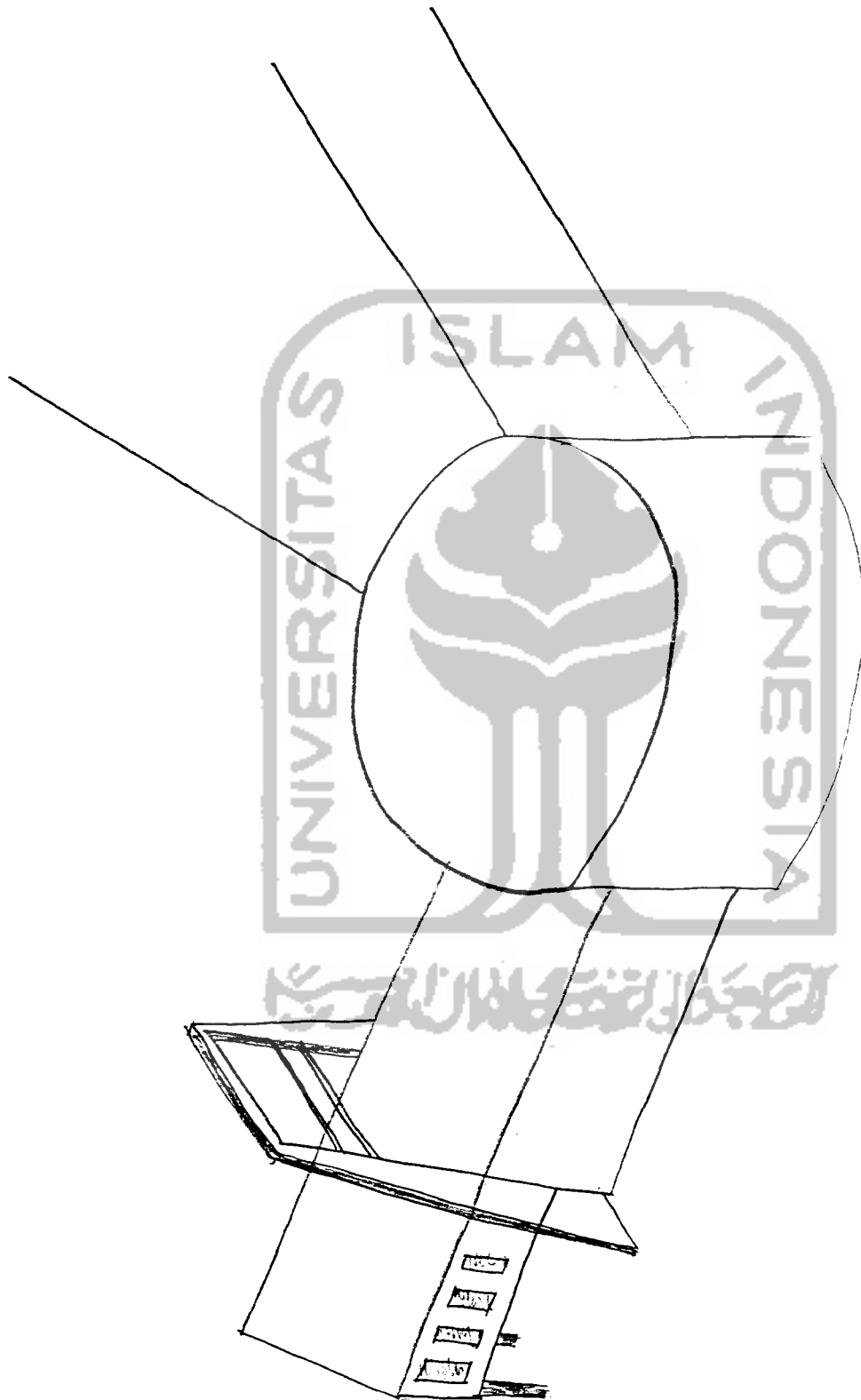
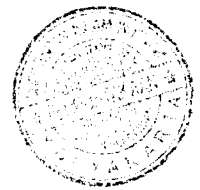



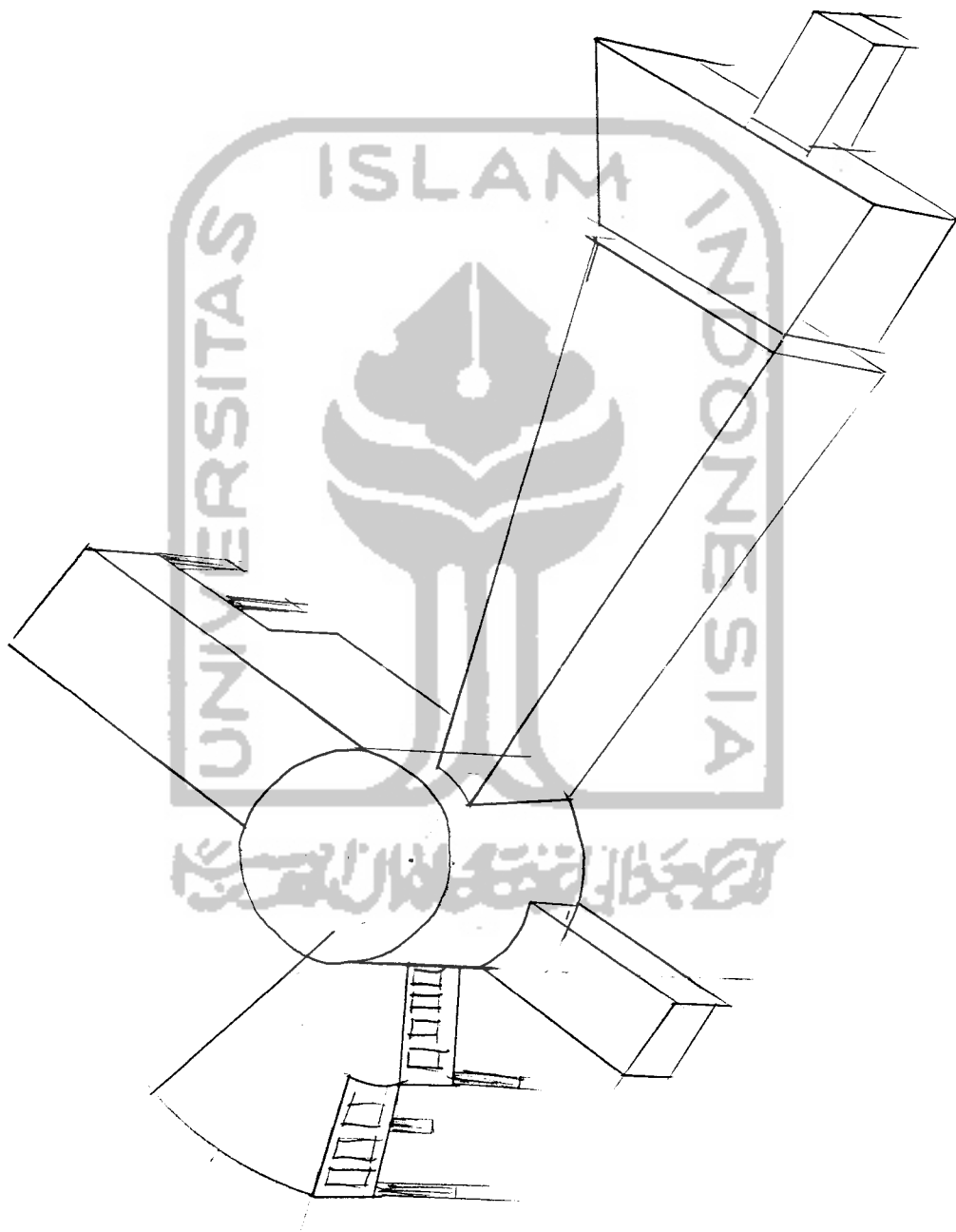

# BENTUK DASAR DESAIN

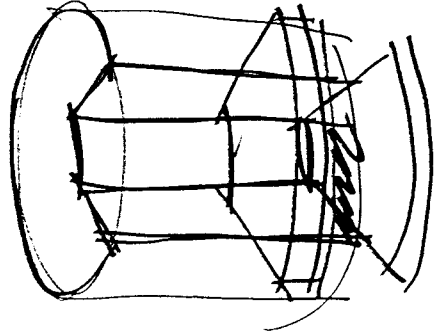
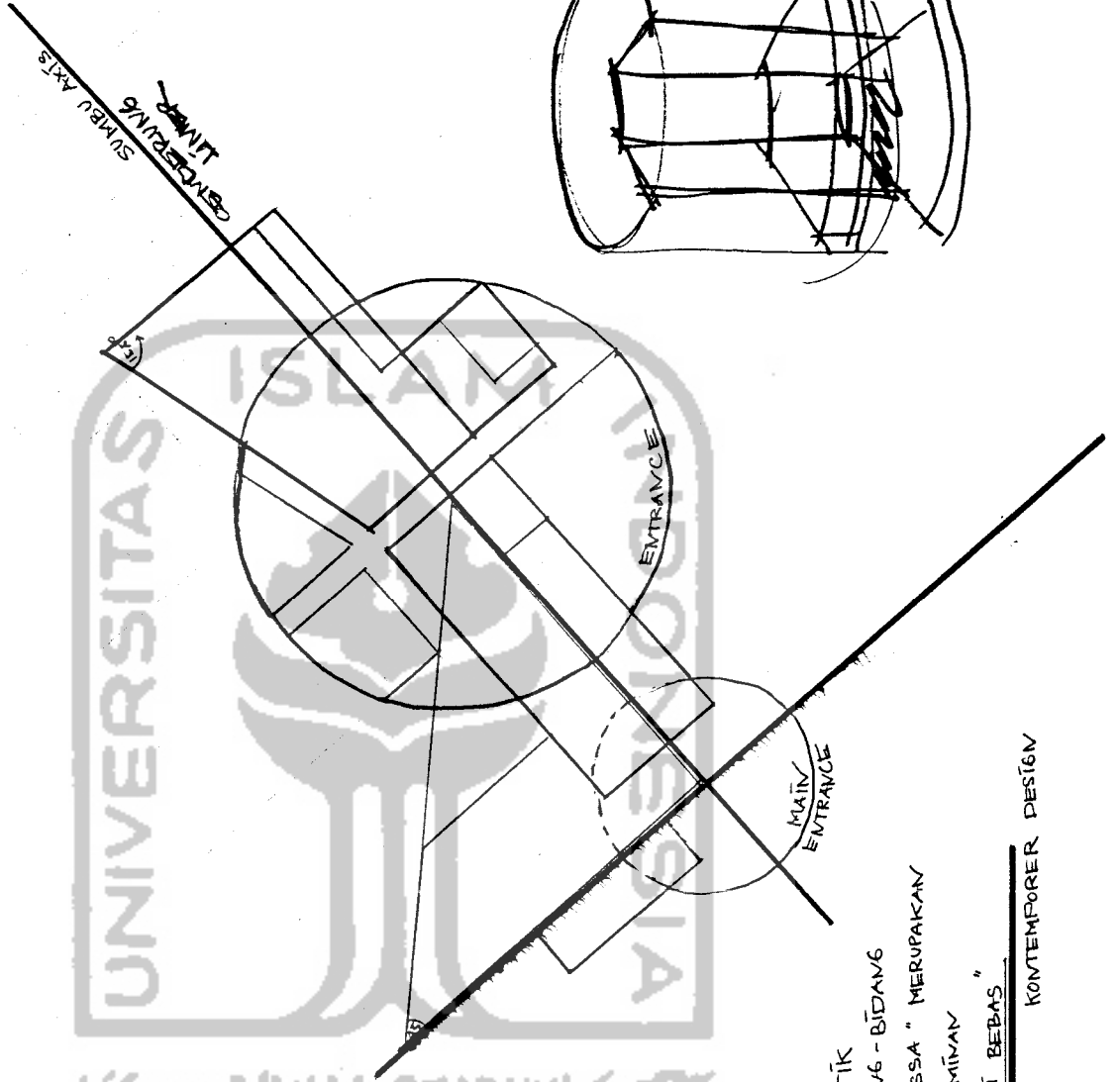
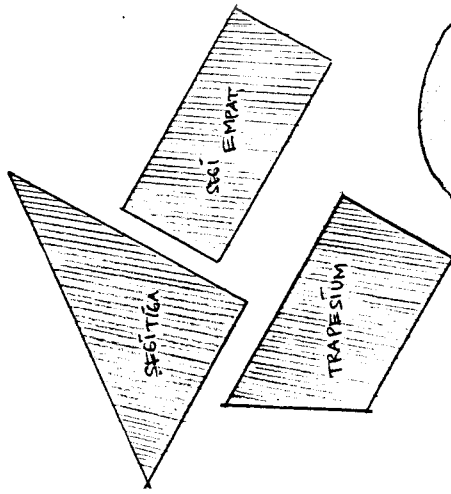

KARAKTERISTIK  
PERMAINAN BIDANG - BIDANG  
DALAM "TATA MASSA" MERUPAKAN  
SALAH SATU CERMINAN  
"EKSPRESI BEBAS"

KONTEMPORER DESIGN

PERMAINAN TINGGI  
RENDAH MASSA  
GABUNGAN.

SETELAH MENGALAMI  
PENGURANGAN & PENGABUNGAN MASSA  
MENGHASILKAN ALT. DALAM PERMAINAN  
BENTUK SUB. MASSA.

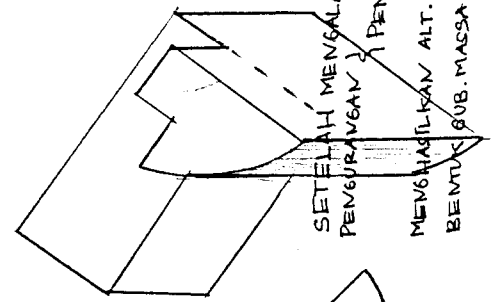
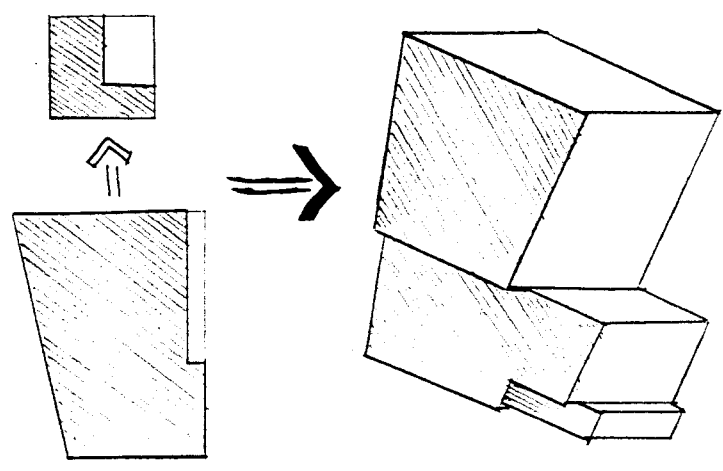

MASSA 'TRAPESIUM' DIDAPAT  
DARI PENGURANGAN BIDANG  
"SEGITIGA SAMA KAKI" SEHINGGA  
UKURANNYA 45° PD SUDUT LANGIT

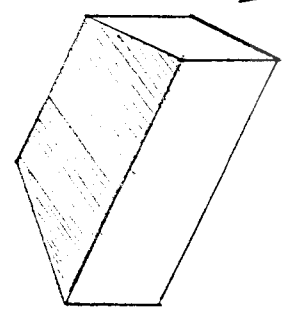
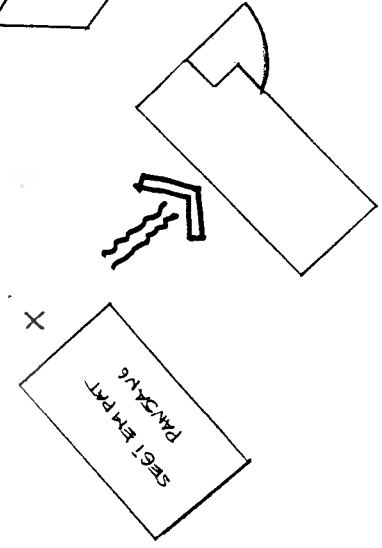
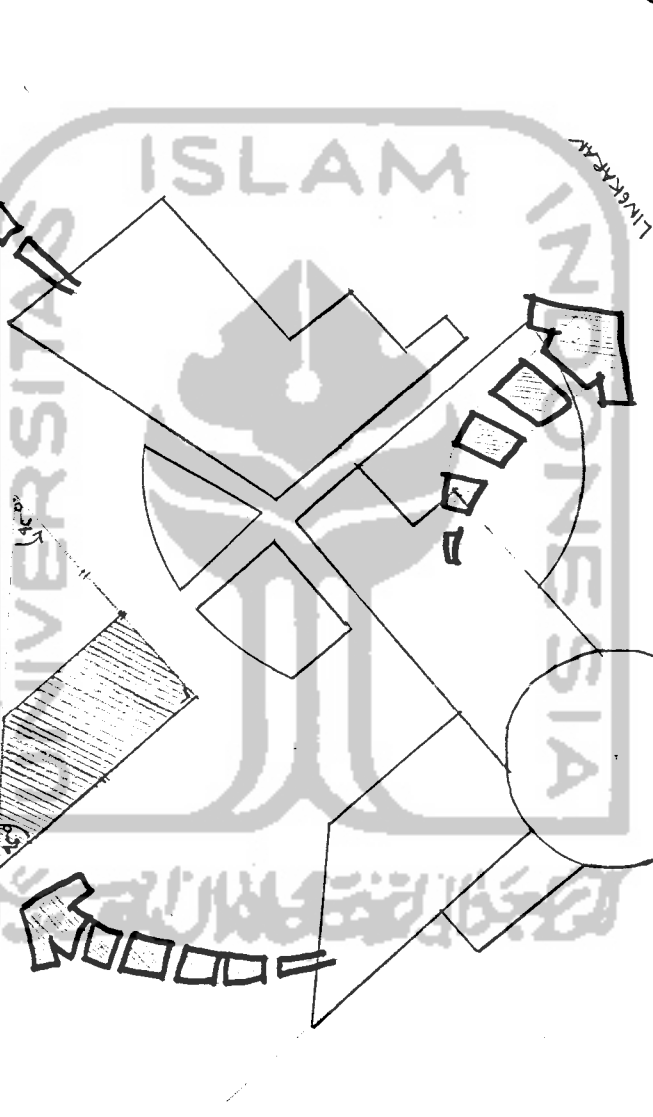

SETELAH MENGALAMI  
PENGURANGAN

LINGKARAN

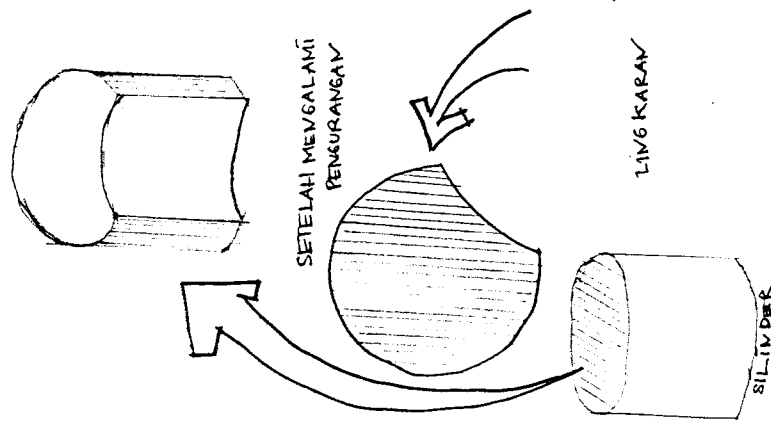

SILIV DOK

# ALTERNATIF FUNKSI BANGUNAN

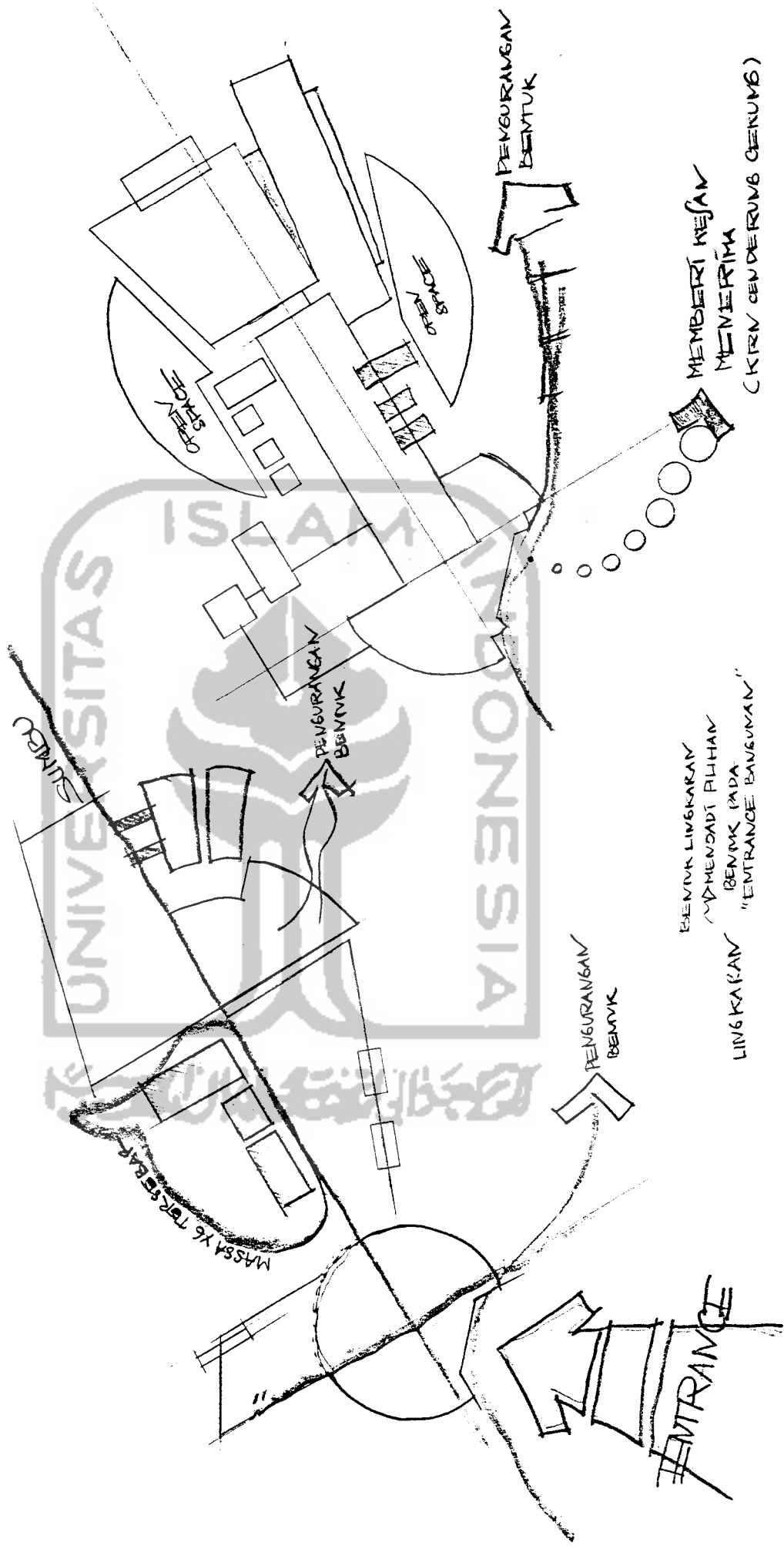

BENTUK LINGKARAN  
MEMENDADI PILIHAN  
BENTUK PADA  
"ENTRANCE BANGUNAN"

MEMBERI KESAN  
MEMERIMA  
(KIRAN CENDERUNG CERUMB)

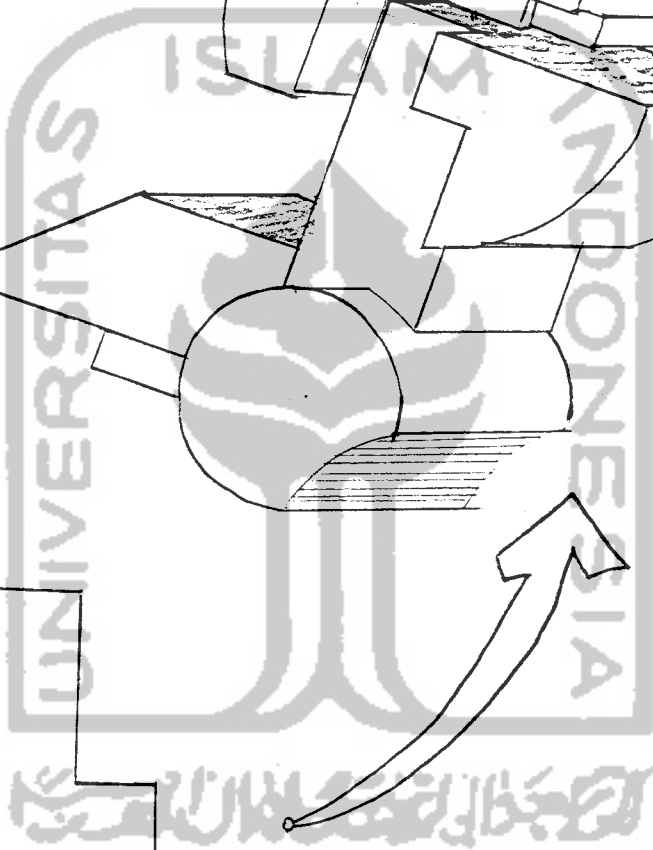
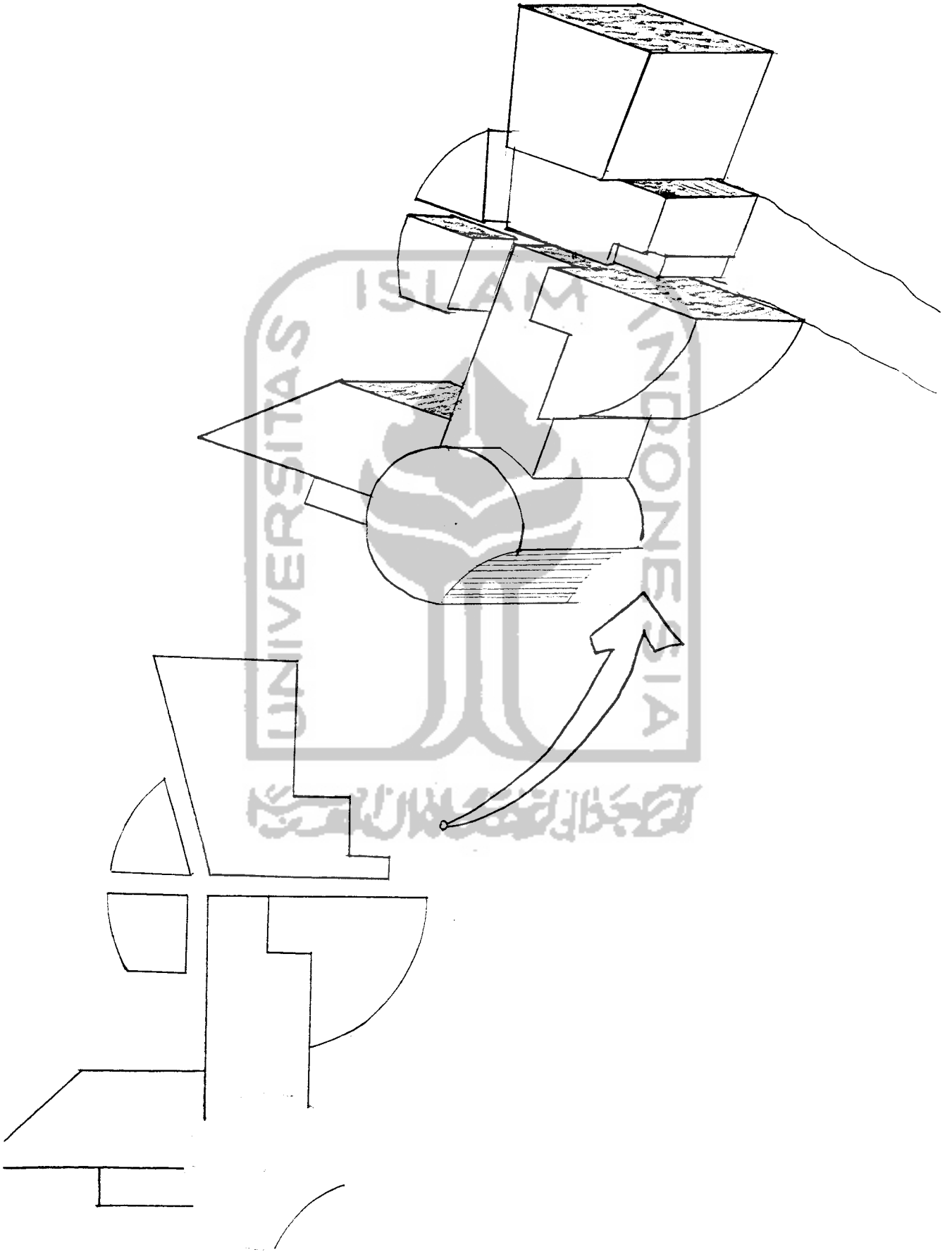





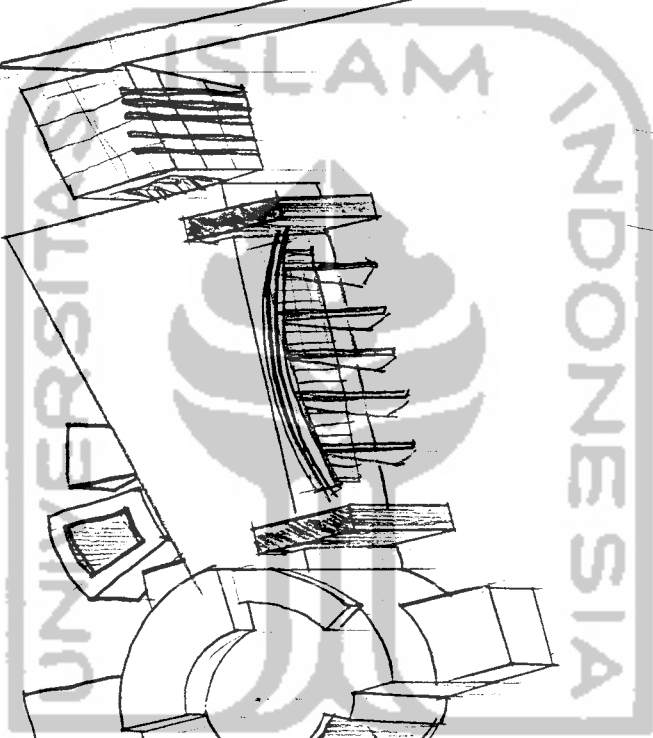
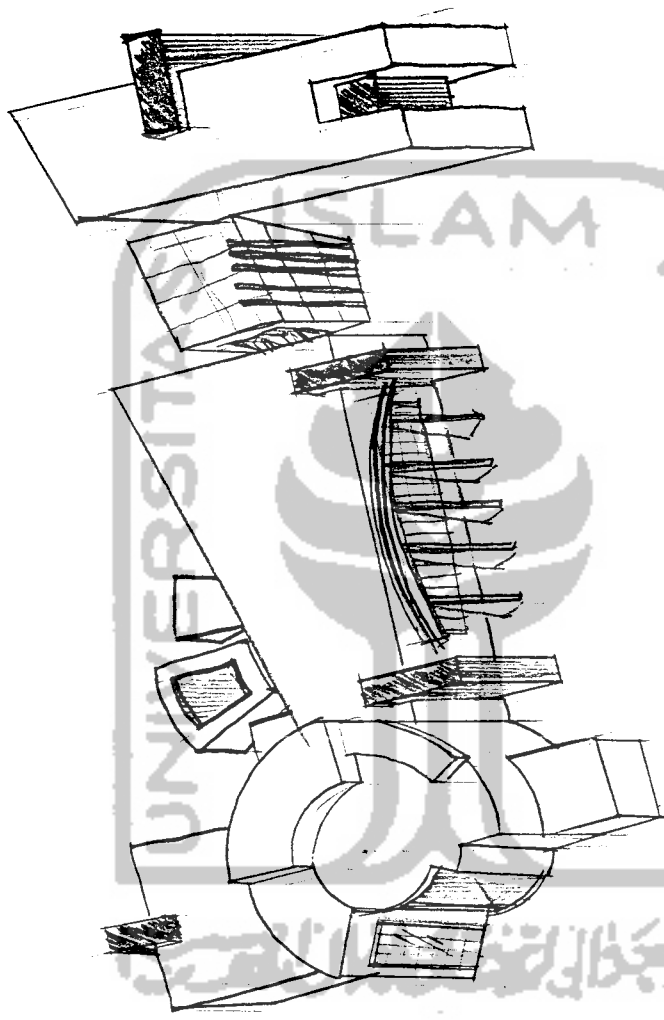

Hand-drawn architectural sketch of a building facade, oriented vertically on the page. The drawing shows a large circular element, possibly a dome or a large window, and a curved balcony or walkway with a railing. The sketch is composed of simple lines and cross-hatching for shading.

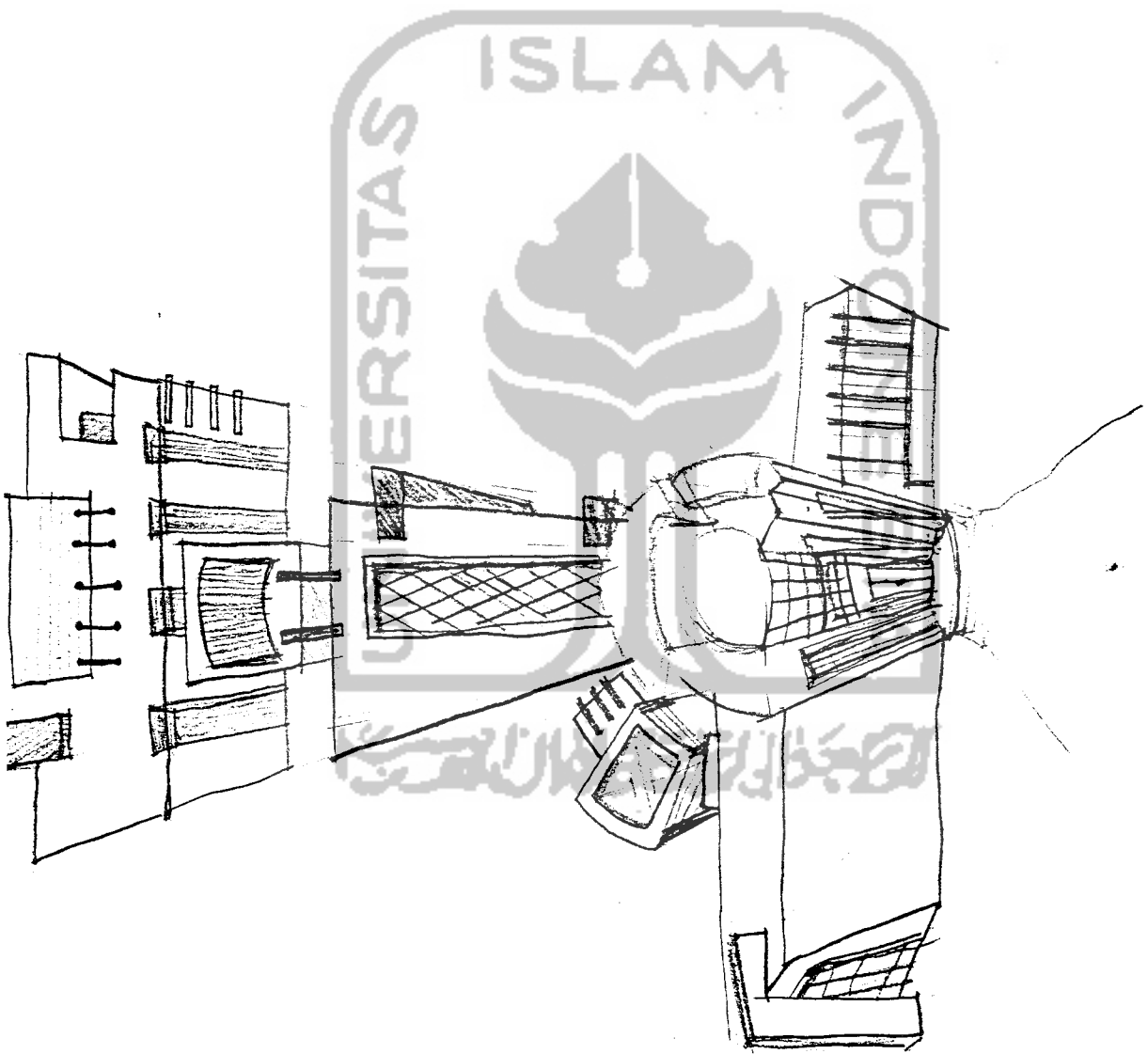

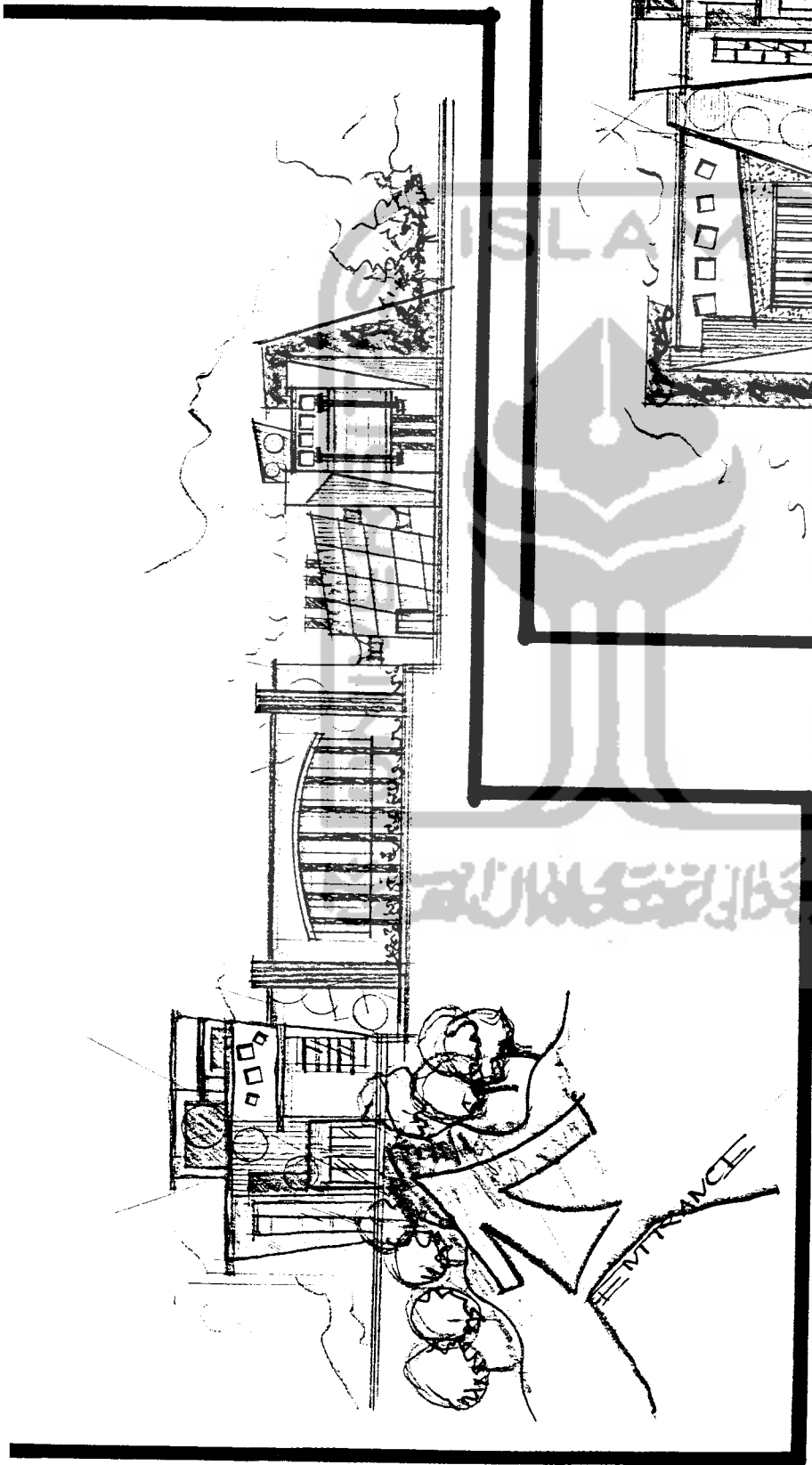
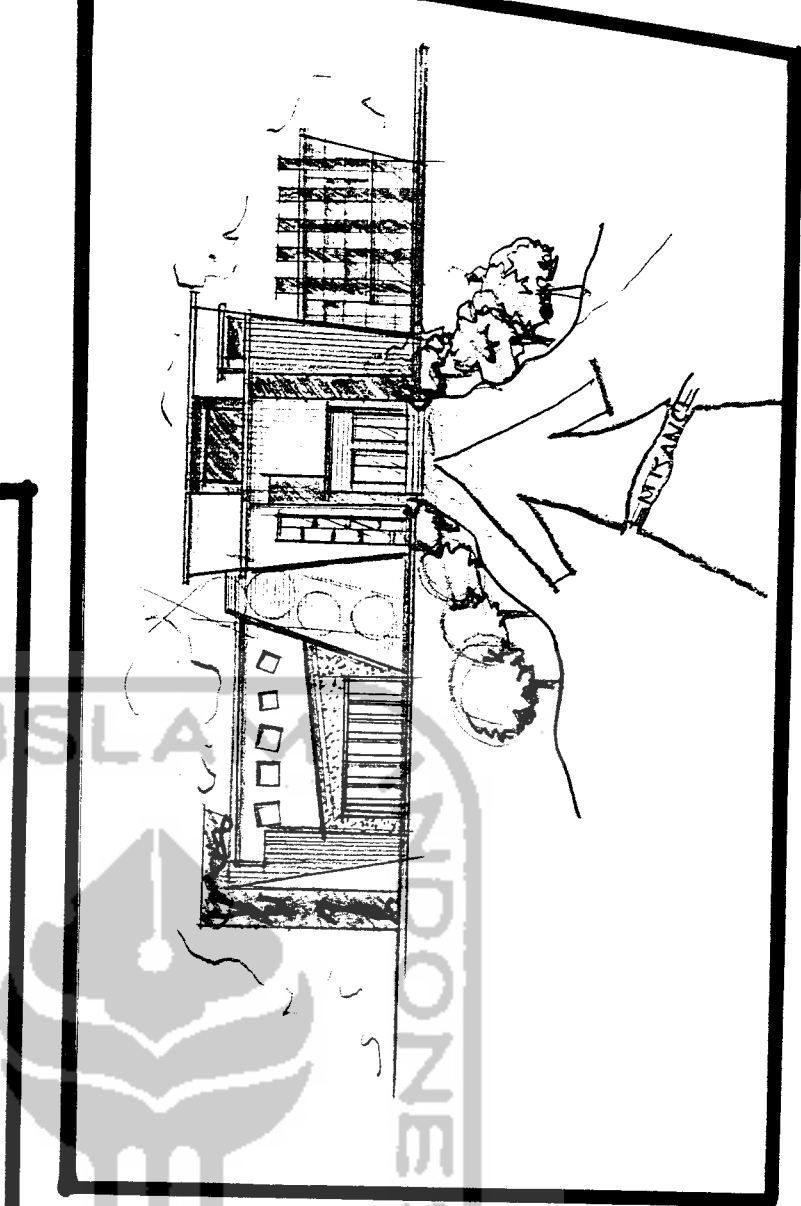

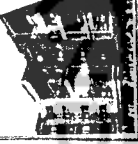
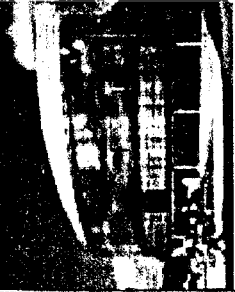

# EXSITEMPORARY

REVISIBILAN BENTUK ATAP, DAPAT DIGUNAKAN SBB ALTERNATIF TRITISAN YANG LEBIH KOMODIT

SIRUKTUR DIEKSPRESI DITUMBUHKAN DAPAT DIDADIKAN ESTETIKA BAKI BANGUNAN, SERTA ADANYA SHADING TRITISAN, ADANYA PENURANGAN BAGIAN BAKI MUSA, BERT KESAU, TIDAK MENYON

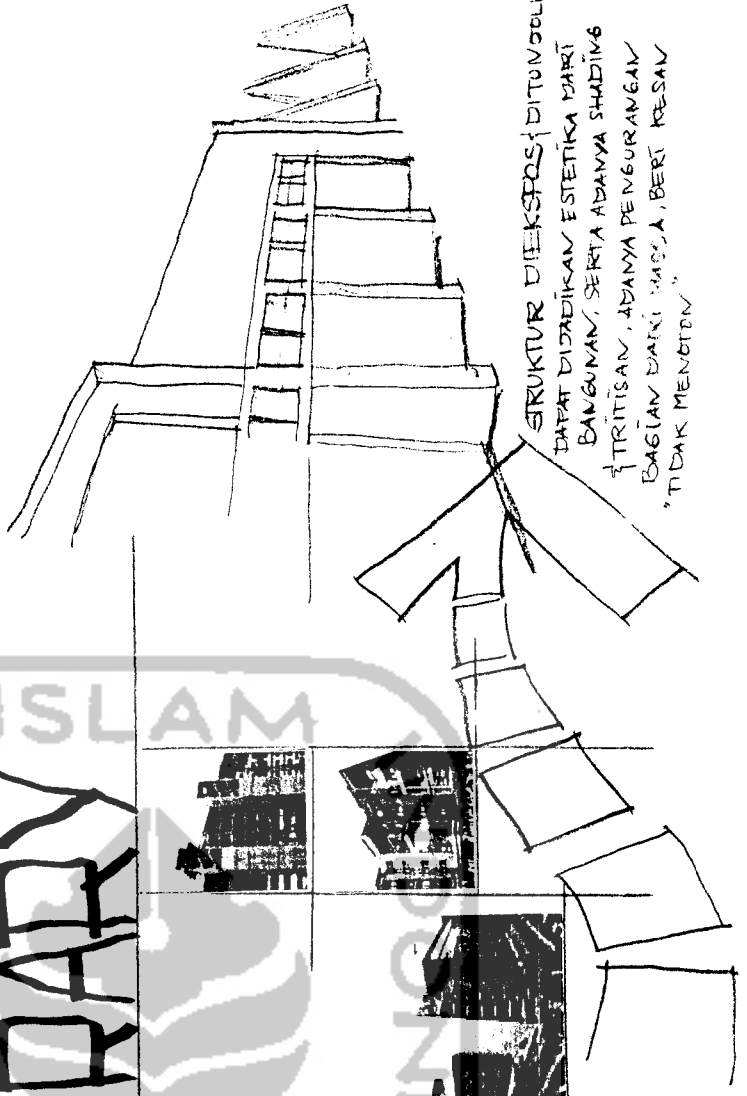
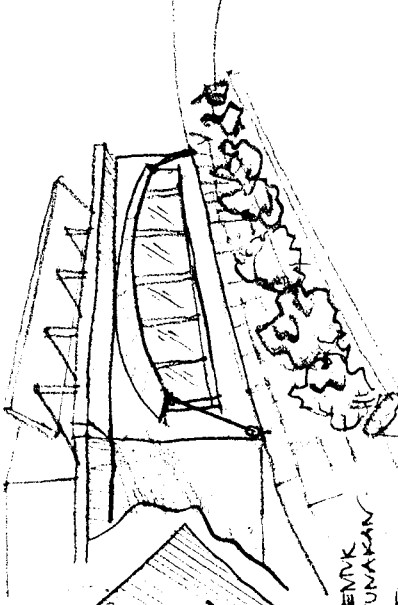

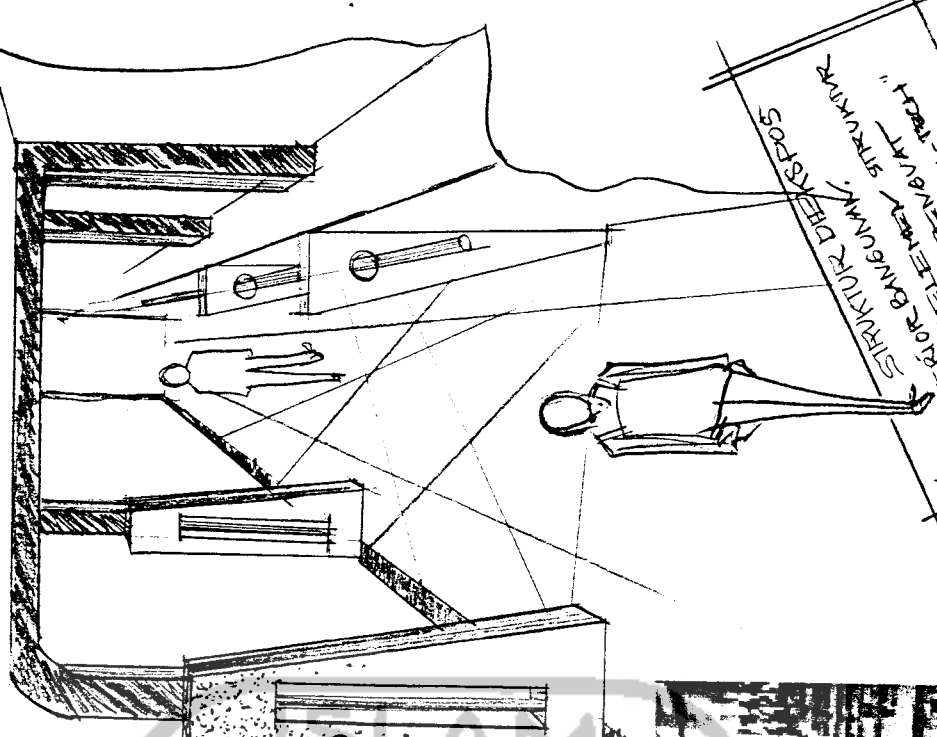

"KONTEMPORER 76-11-1984"  
"BAYU MENYALU TENGAH"  
"REHABILITASI TENGAH"  
"STRUKTUR BANGUNAN"  
"STRUKTUR DEKORATIF"  
"STRUKTUR DEKORATIF"

PERMAINAN  
TEKSTUR PD  
DINDING, SEG  
KINETIK KHAS  
KONTEMPORER

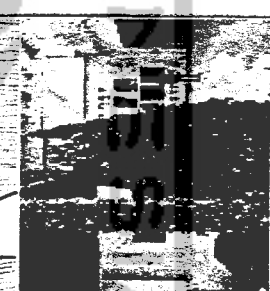

# CONTEMPORARY INTERIOR

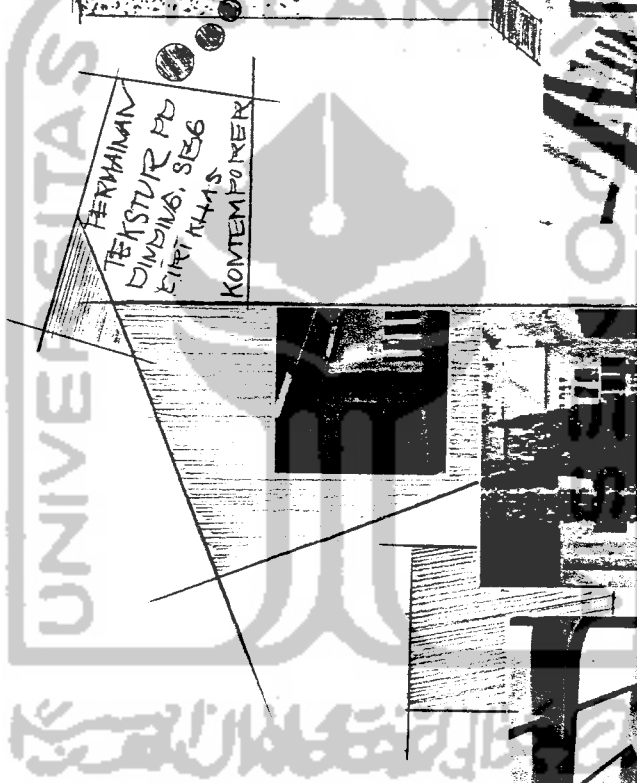

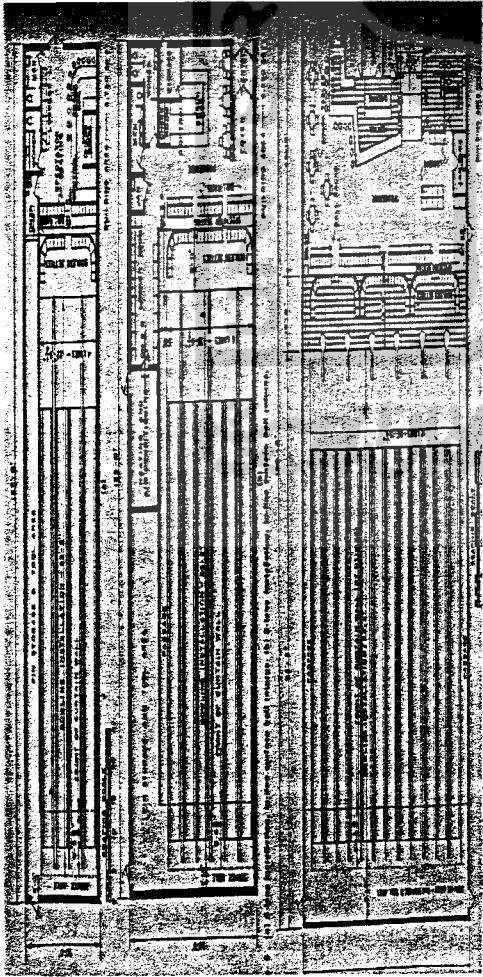

# BOWLING ALLEY

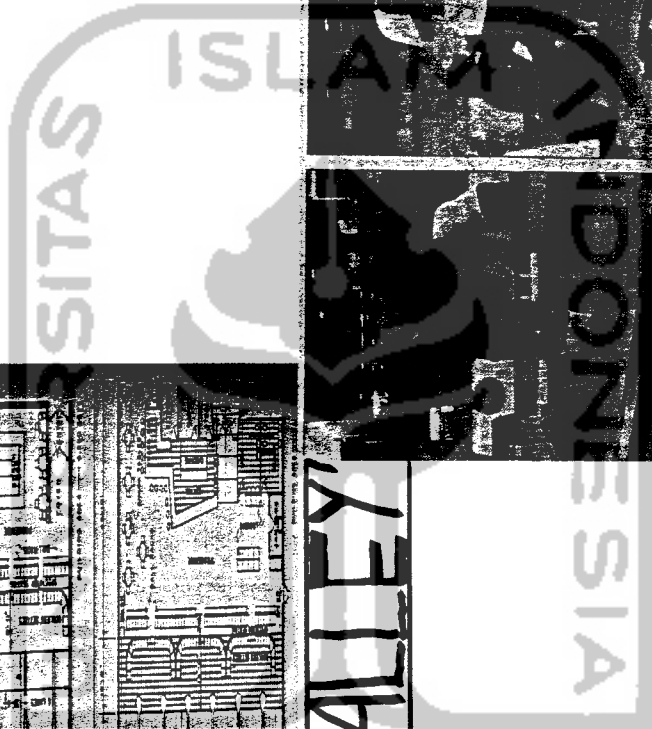

# BASKETBALL AREA

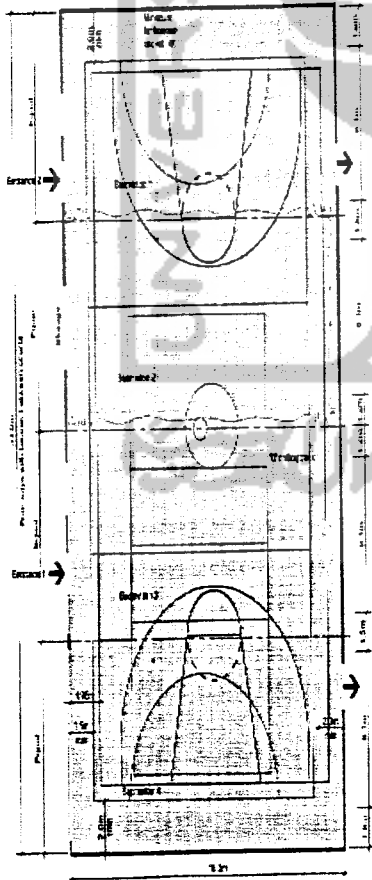

A23-16 (7/2019)-court1a

# SQUASH AREA

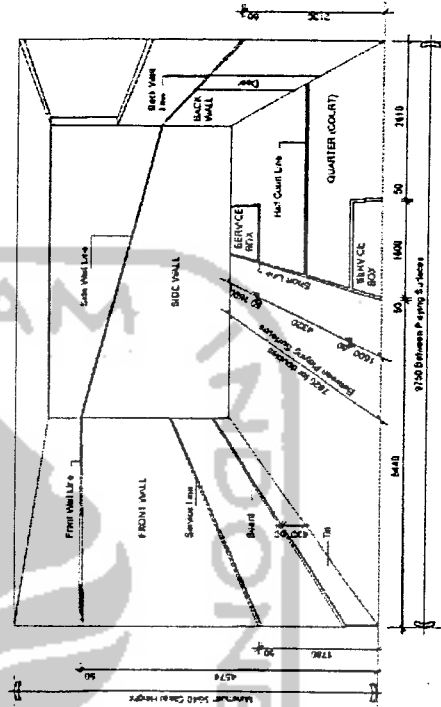

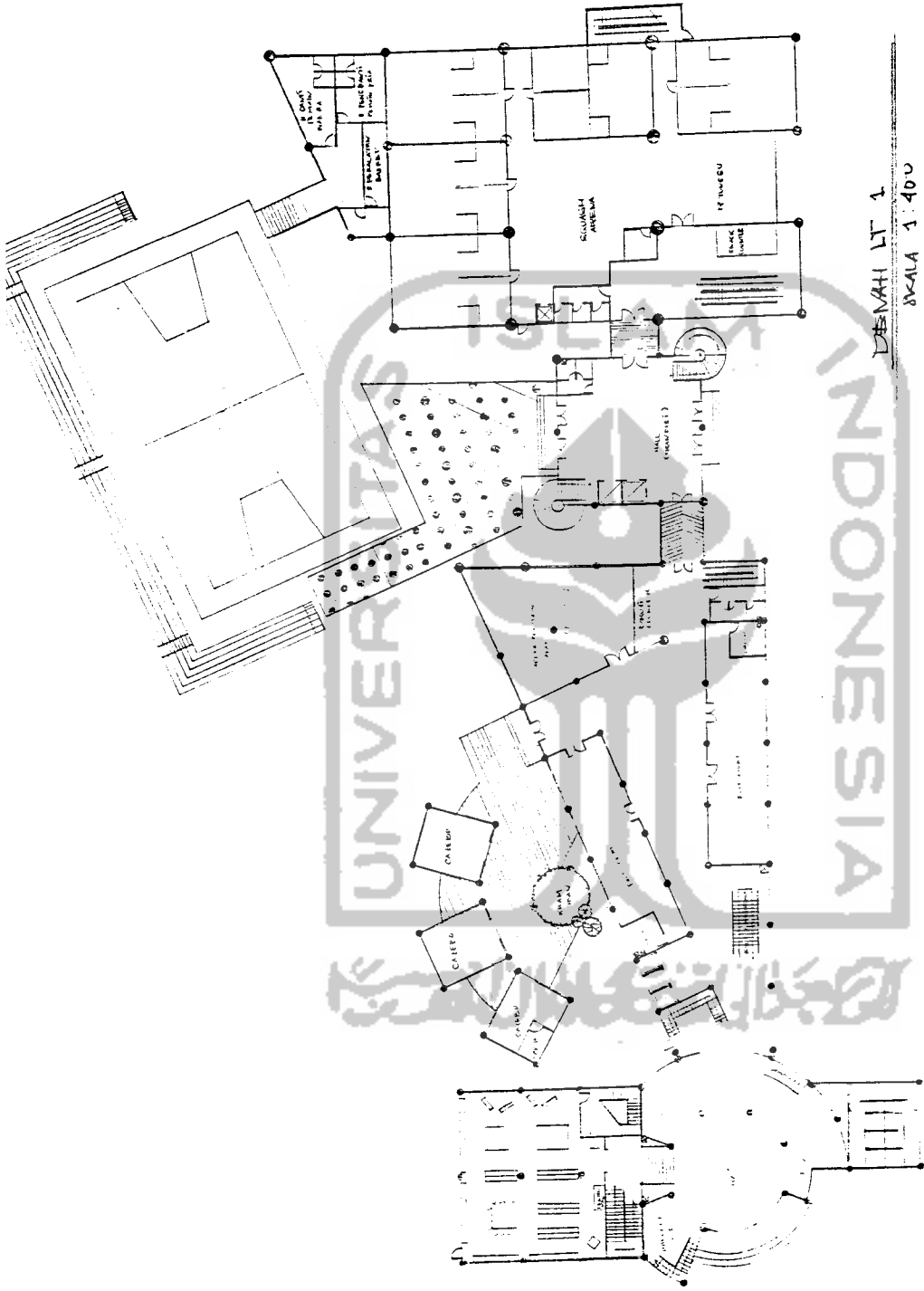

DENAH LT 1  
SKALA 1:400



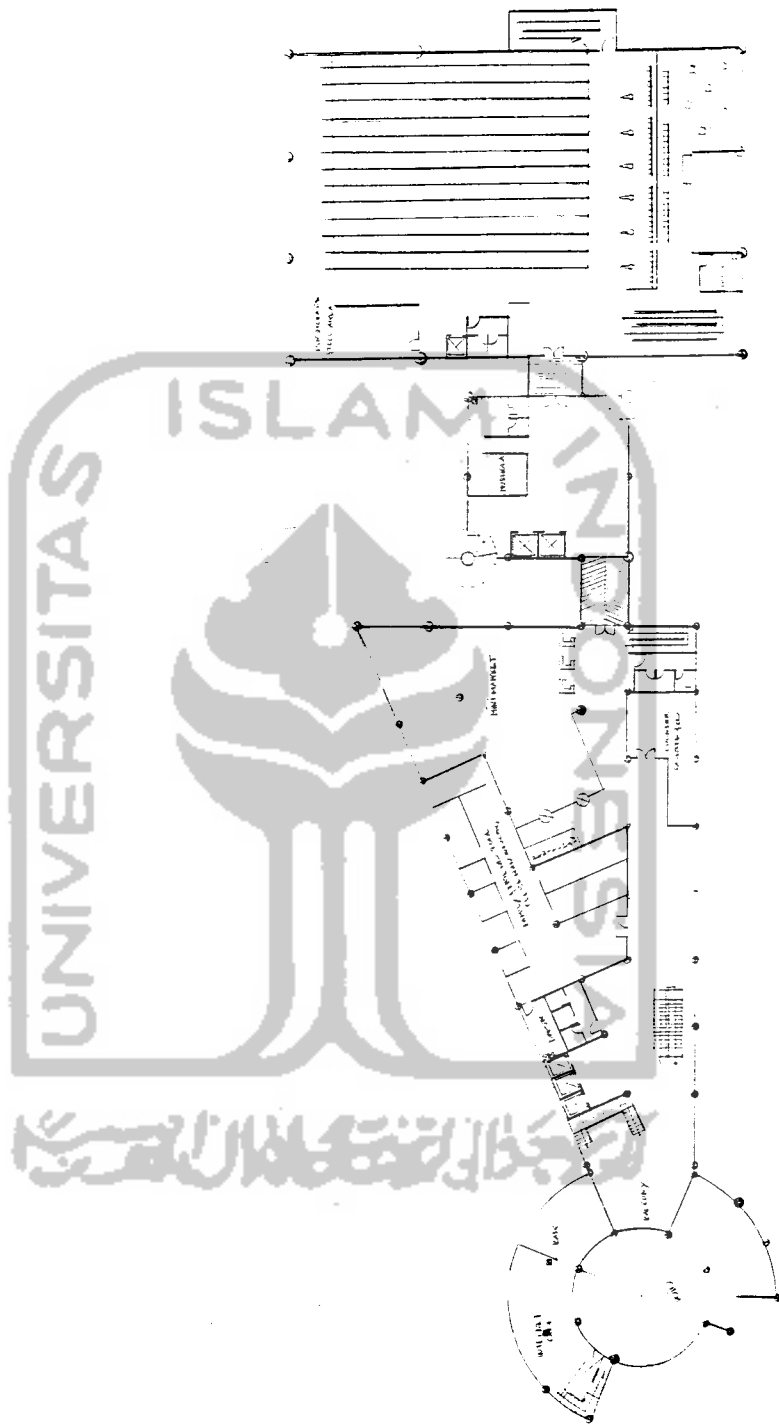

DENAH IT. 2  
 SKALA 1:100

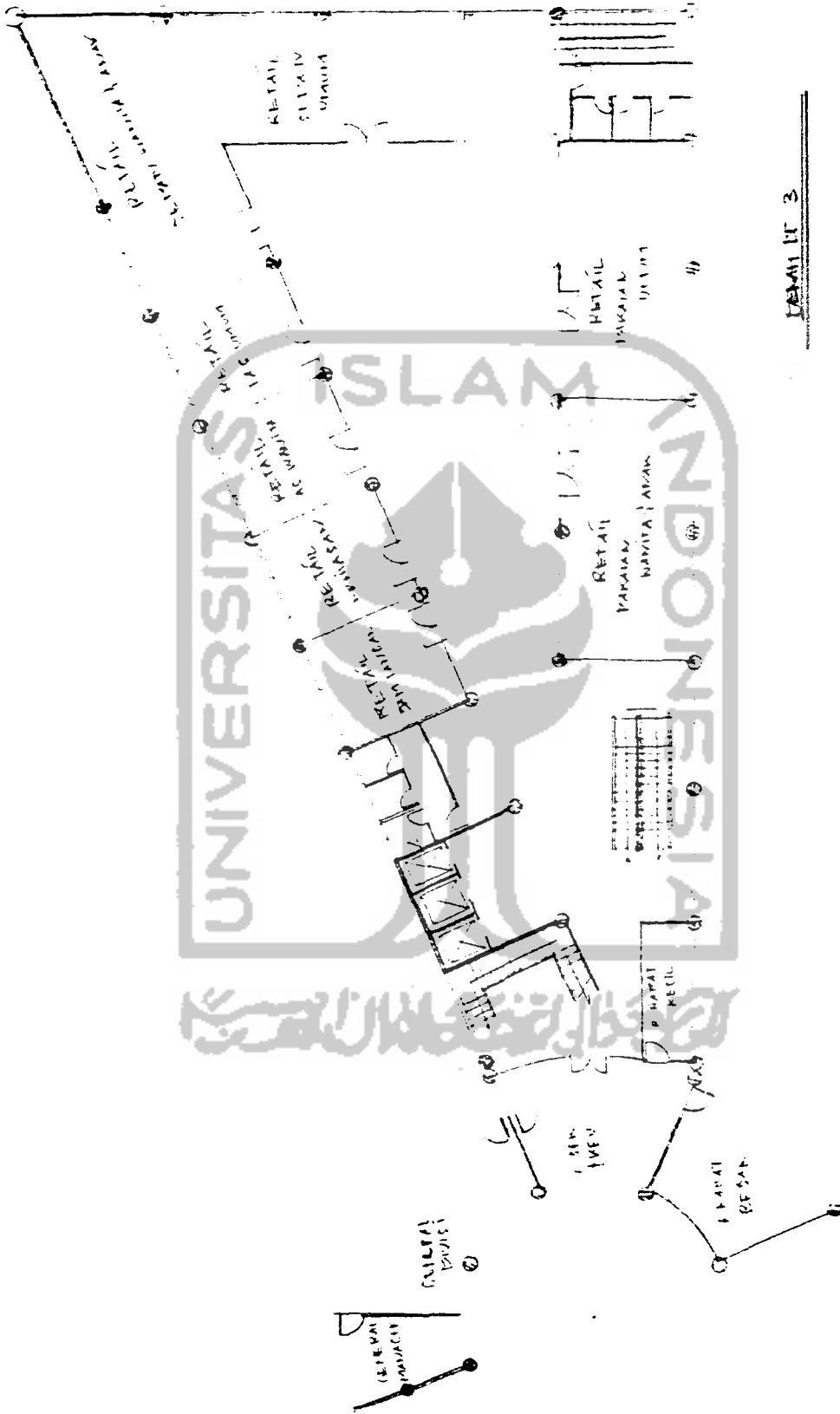

LEMAH IT 3



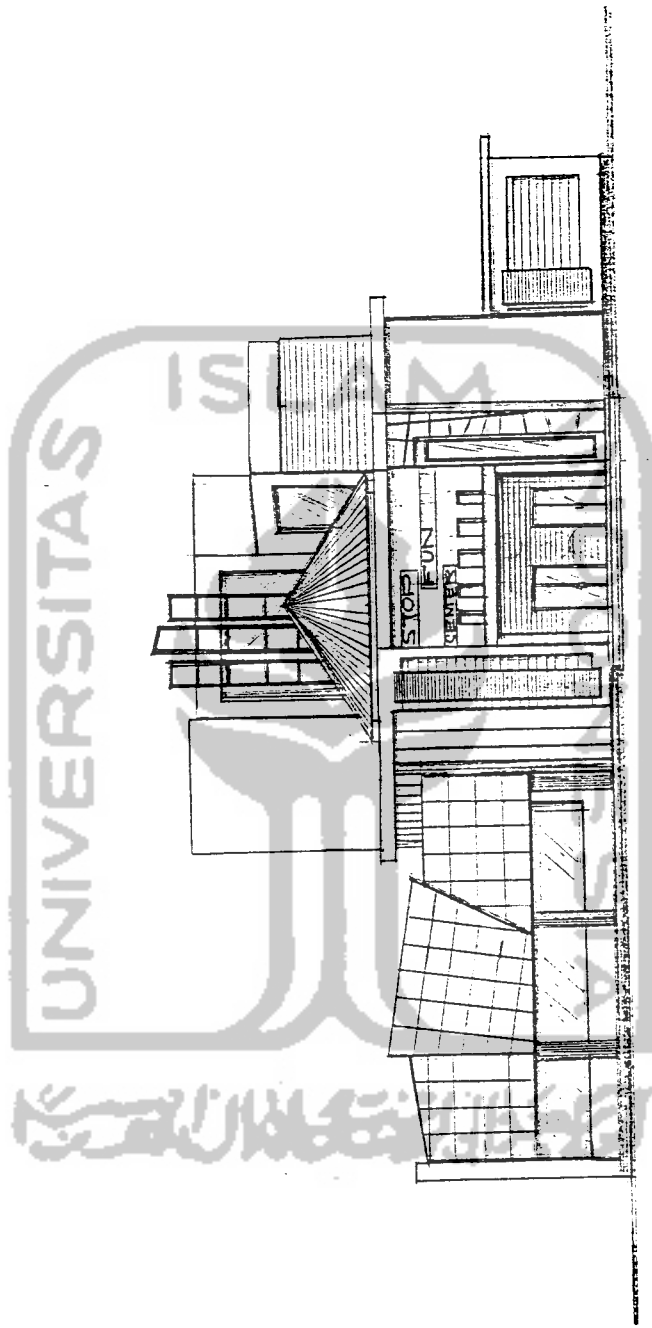

TAJANIK MAIN ENTRANCE



جامعة الإسلام

