

## BAB II

### PERSYARATAN TEKNIS FUNGSIONAL

Religius center ini menampung kegiatan kegiatan yang berkaitan dengan masalah keilmuan yang berupa pengkajian masalah masalah spiritual (media komunikasi dan dialog) .

Pada fungsi yang mengikat, Bangunan ini dapat digunakan untuk semua agama dengan batasan bahwa pada tempat ini tidak ada pengklasifikasian tempat-tempat ibadah (rumah ibadah) untuk sembahyang misalnya mesjid, gereja, wihara, dan pura. Jadi kegiatan keagamaan yang ditampung adalah kegiatan perayaan hari raya berskala besar dengan pengguna diatas 250 orang, hanya terjadi pada waktu waktu khusus atau temporer sesuai dengan perayaan hari-hari besar masing-masing agama.

Selain kegiatan keilmuan dan kegiatan ritual seperti tersebut di atas Religius Center ini menampung juga kegiatan kegiatan seperti; kegiatan keorganisasian, kesenian, olah raga, dan klinik kesehatan jiwa. Untuk mendukung operasional bangunan maka bangunan ini mempunyai fasilitas pendukung dan asrama.

#### Klasifikasi Bangunan

##### 2.1 Bangunan Tempat Dialog Antar Agama

Pada bangunan ini fungsi yang ditampung adalah kegiatan dialog berupa diskusi, keorganisasian, pendidikan, penelitian.

Ruang-ruang yang dibutuhkan berupa kelas kelas diskusi, auditorium, kantor pengelola, perpustakaan dan laboratorium.

- o Kelas-kelas diskusi

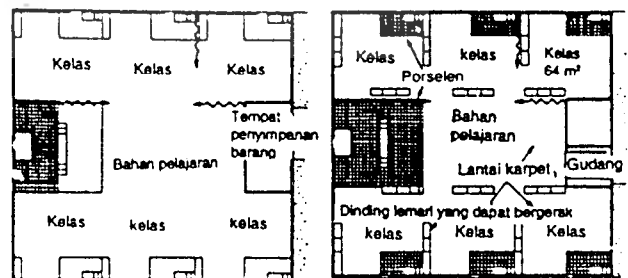

- 1 Ruangn belajar tanpa dinding (pemisah)
- 2 Pembagian kelas dengan dinding lemari yang bergerak

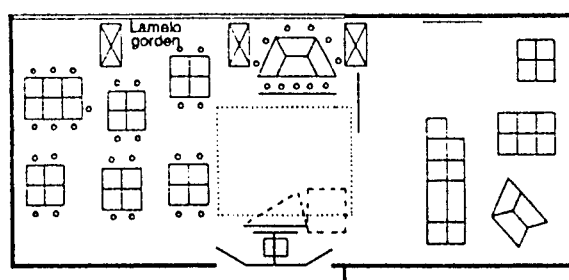

- 3 Sekolah bersama, Tannenberg Seeheim

o Ruang-ruang seminar

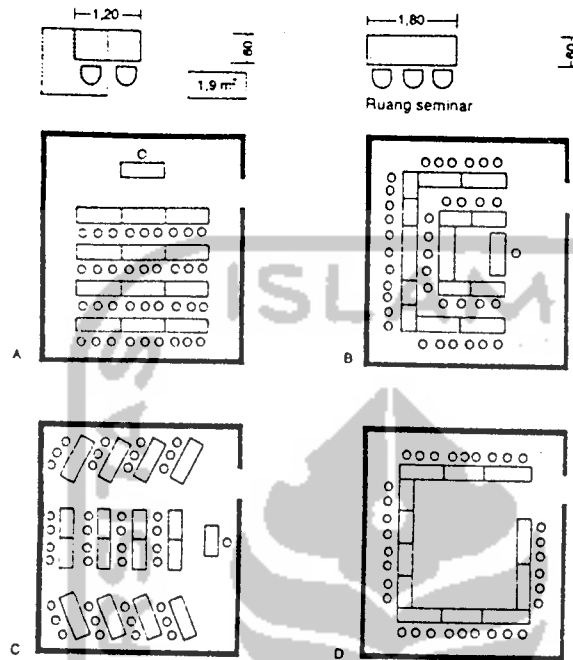

① Ruang seminar, susunan bangku yang bervariasi

o Auditorium

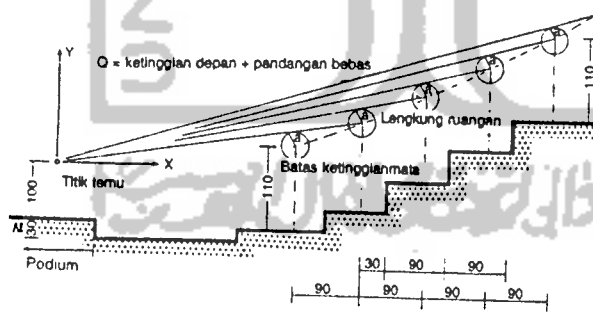

Batas gambaran grafik pendengar

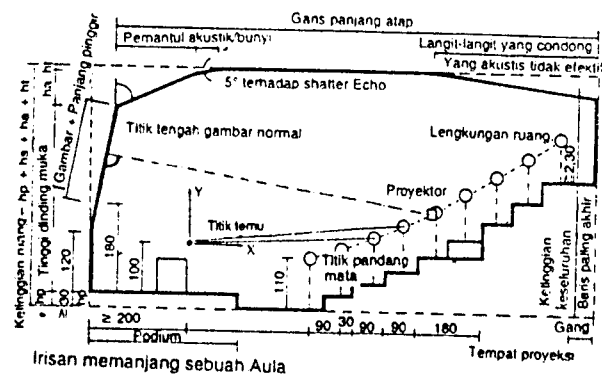

o Perpustakaan

Standar penataan ruang perpustakaan

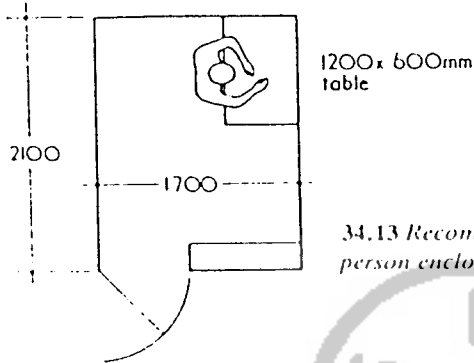

34.13 Recommended single person enclosed carrel

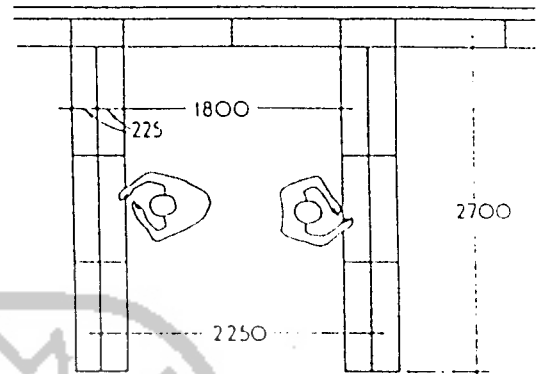

34.18 Recommended minima for open access bookshelf arranged as alcoves

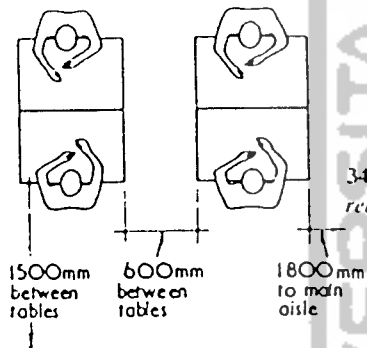

34.14 Minima for dual reading tables

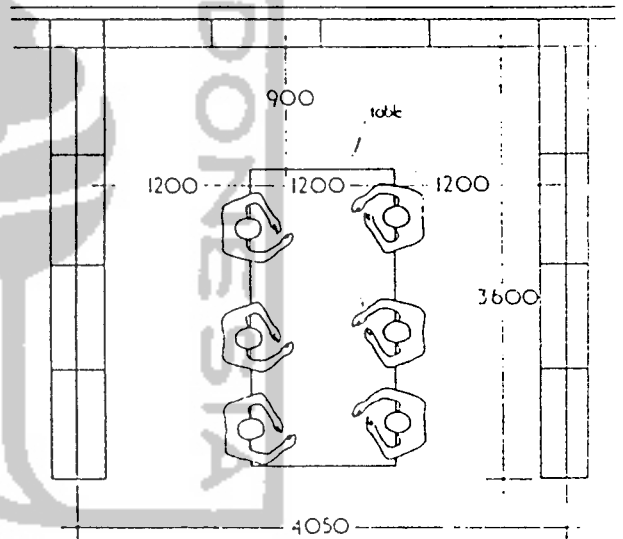

34.19 Recommended minima for open access bookshelf arranged as alcoves containing reading tables

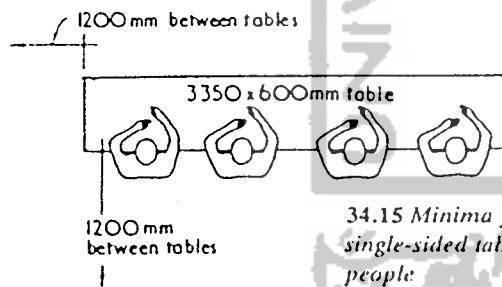

34.15 Minima for single-sided tables for four people

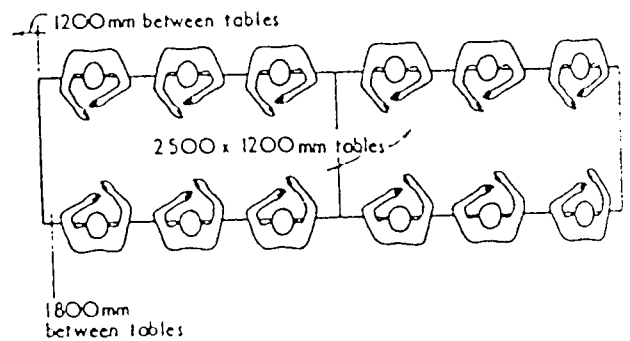
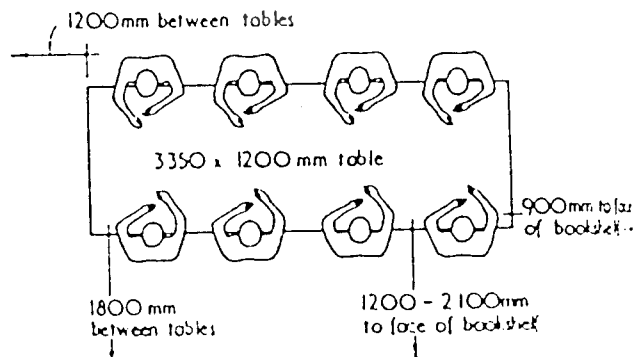

## 2.2 Bangunan untuk kegiatan keagamaan

Kegiatan keagamaan yang diwadahi kegiatan ibadah (sembahyang) dan kegiatan peringatan perayaan hari-hari besar agama. Ruang yang dibutuhkan adalah ruang konvesi tertutup dan secara fleksibel bisa berhubungan secara langsung dengan ruang luar.

Hari-hari besar yang ditampung kegiatannya adalah: Idul Adha, Nyepi, Tahun baru Hijriyah, Wafat Isa Al Masih, Waisak, Kenaikan Isa Al Masih, Maulid Nabi Muhammad SAW, Isra' Mi'raj Nabi Muhammad SAW, Idul Fitri, dan Natal Hari pertama.

Di bawah ini akan ditampilkan besaran dan standar ukuran dalam beberapa kegiatan ritual.

- Besaran dan Standar ukuran dalam Ritual Sholat

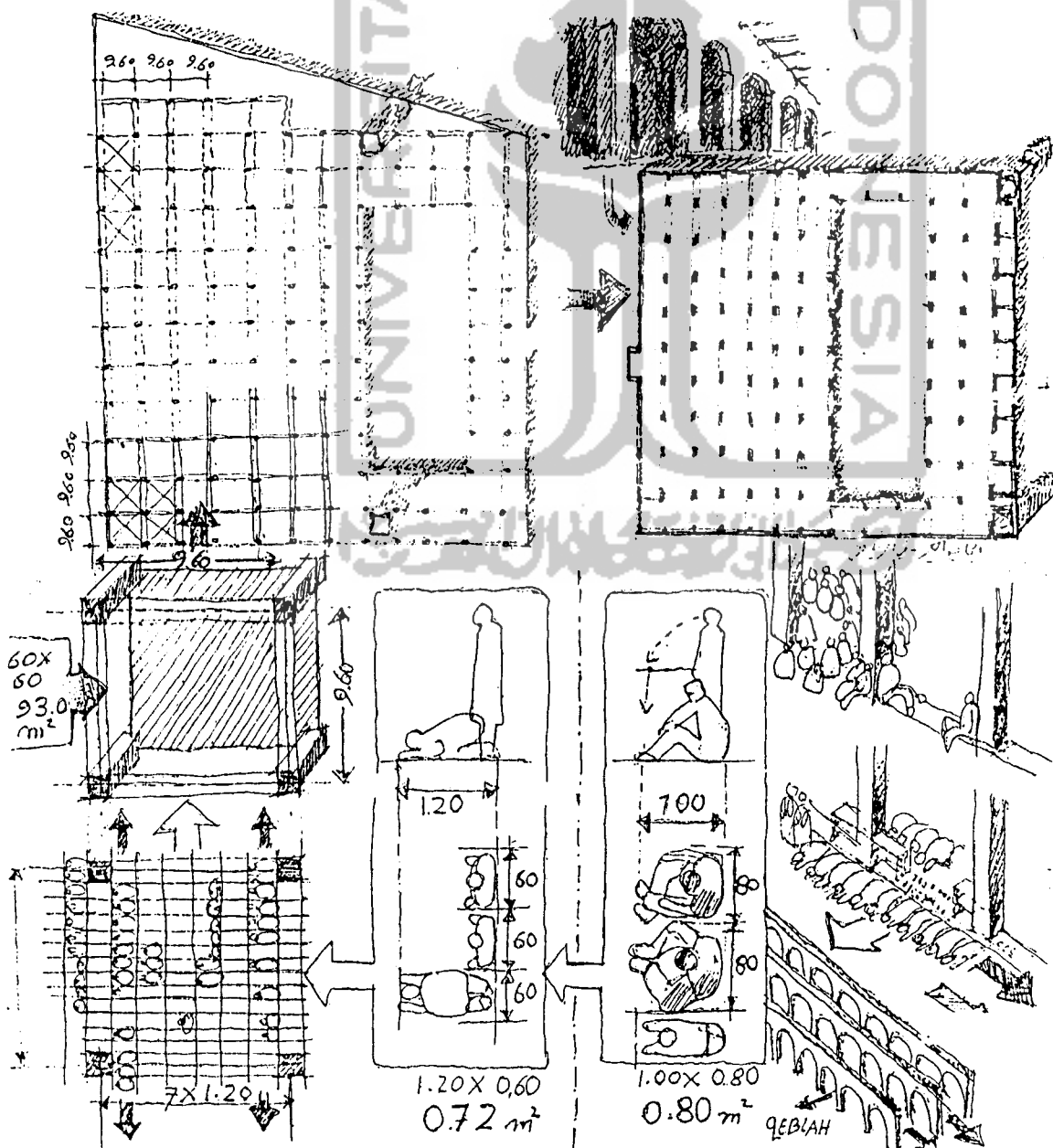

- Besaran dan standar ukuran pada kegiatan Liturgi dalam Gereja

- Perbandingan besaran kebutuhan ruang antara Chancel, Seating dan Narthex.

Chancel : ruang di sekitar altar untuk tempat para imam dan paduan suara, sering dengan lantaib yang ditinggikan dan disekat dengan tirai, railing atau partisi.

Seating : pada tempat ini terdapat nave yaitu lorong utama suatu gereja yang merupakan tempat prosesi keagamaan da aisle lorong samping yang mengapit nave.

Narthex : serambi depan sebelum memasuki nave.

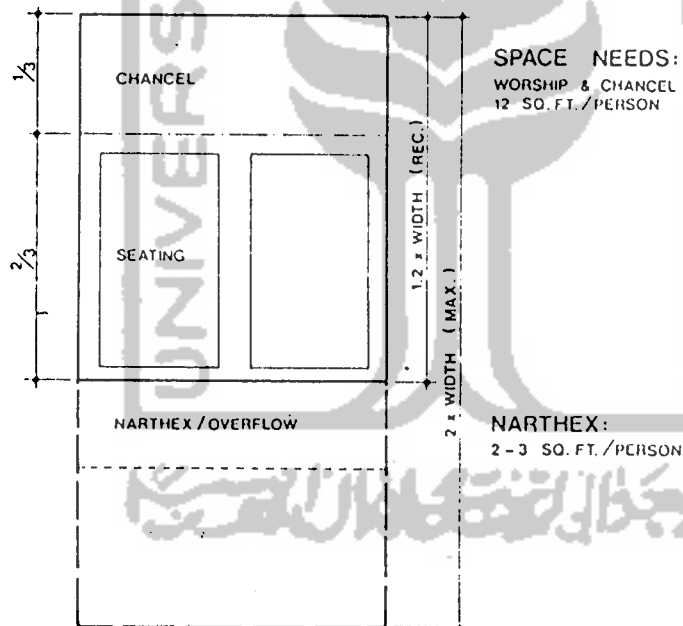

- o Besaran dan ukuran, sesuai kegiatan yang terjadi pada aisle.

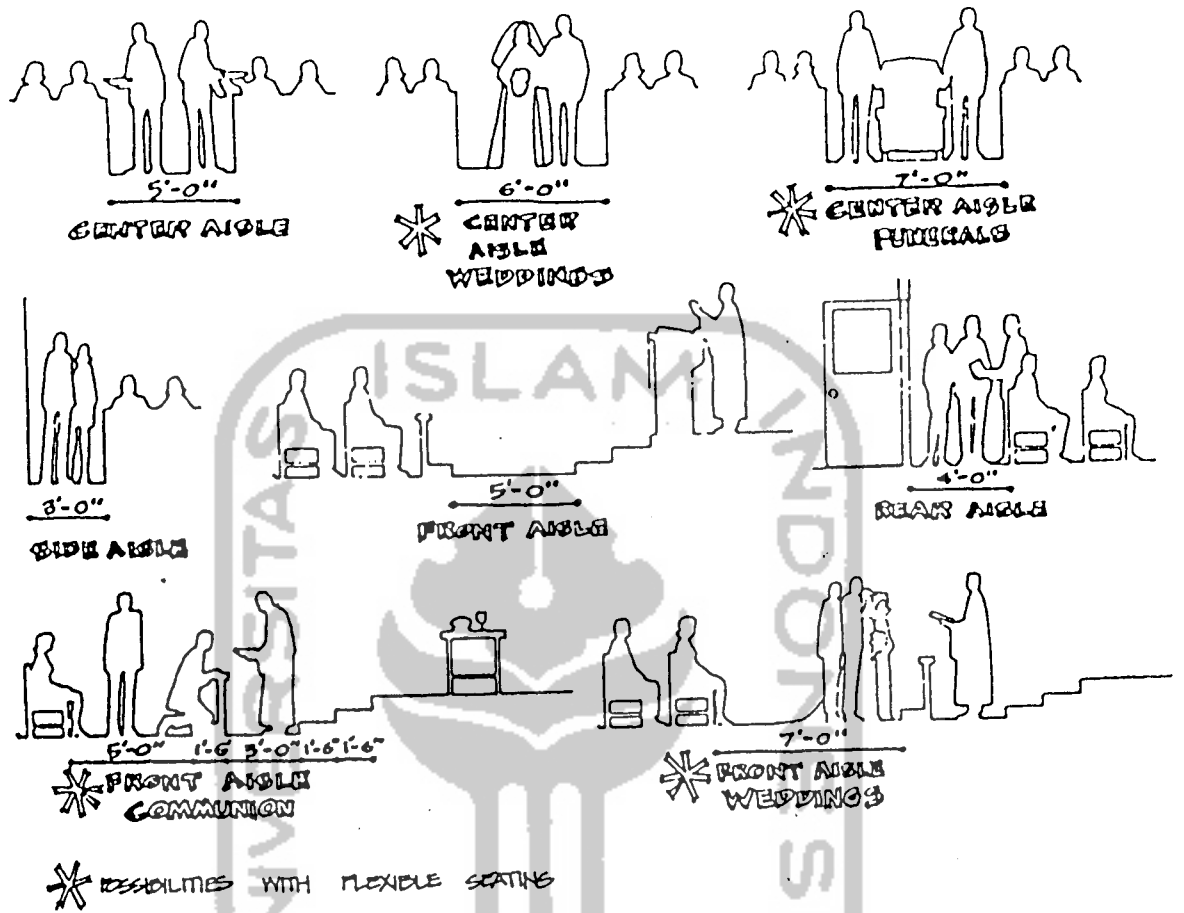

- o Pola-pola layout kegiatan-kegiatan liturgi dalam gereja.

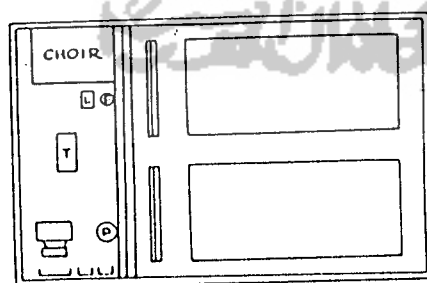

**A. FORMAL WORSHIP**  
All furnishings are portable with the possible exception of the organ console. The emphasis is upon the pulpit, table and font. The nave seats 240 and the choir from 21 to 24.

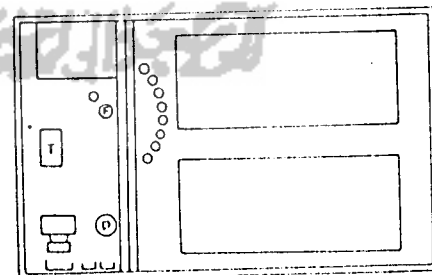

**B. BAPTISM**  
The pastor and the one being baptized would stand on the level of the chancel platform so the ceremony could be seen by the congregation. The parents and sponsors would stand before the font on the nave floor.

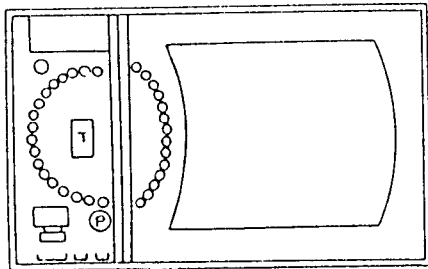

**C. COMMUNION**

Communion is served by the pastor to the congregation as they stand around the table. The center aisle has been eliminated and the rows of chairs placed 42" apart allowing 20" per person.

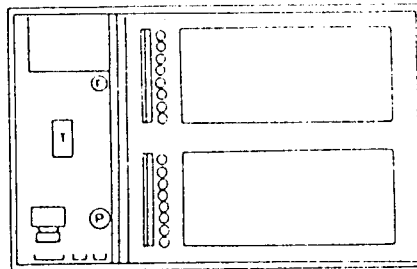

**D. COMMUNION**

The communicants are served by the pastor at a portable communion rail and kneeling step. The rows of chairs in the nave are spaced 32" apart allowing 18" per person.

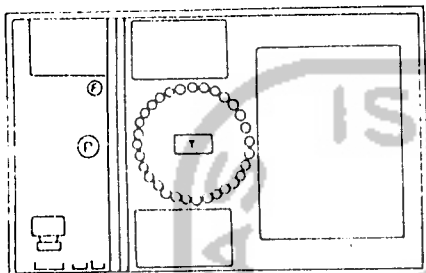

**E. COMMUNION**

The communion table has been moved down into the nave with the congregation grouped around it. The pulpit has been moved to the center of the chancel platform. Communion could be served standing or the portable rail and kneeling step could be used for kneeling.

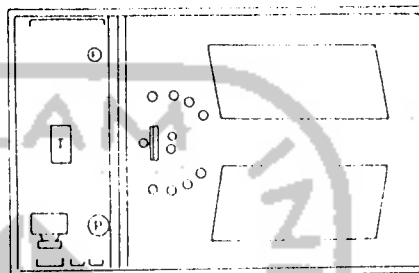

**F. WEDDING**

The width of the center aisle has been increased from 5' to 7' and the width of the front cross aisle increased to allow adequate space for the bridal party and pastor. A prayer desk or prie-dieu is used for kneeling. This plan seats 98 although the capacity could be increased.

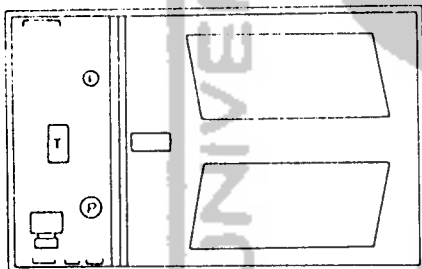

**G. FUNERAL**

The width of the center aisle has been increased to 7' to allow the pallbearers to bring in the casket. The actual seating capacity would depend upon the need. The normal practice is to place the casket as indicated, perpendicular to the table.

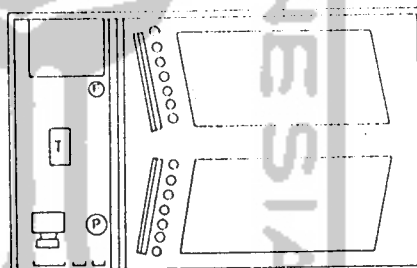

**H. RECEPTION OF MEMBERS**

Those being received in membership are shown at the communion rail. The same arrangement would serve a confirmation service where kneeling is required.

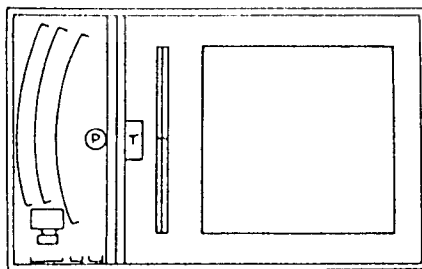

**I. EVANGELISTIC MEETING**

The congregation has been grouped together in front of the pulpit, which has been placed in the center of the chancel. The choir is grouped in back of the pulpit. The communion table and rail are forward of the pulpit.

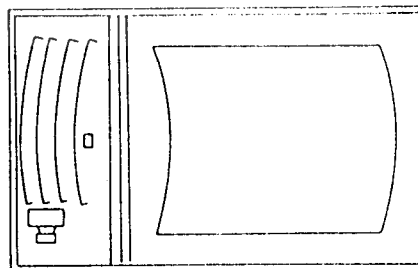

**J. CHOIR PROGRAM**

The choir is grouped together on the platform facing the choir leader and congregation. Special choir programs (cantatas, oratorios, etc.) are popular in many parts of the country. There is considerable freedom in these plans in providing space for instrumentalists near the choir.

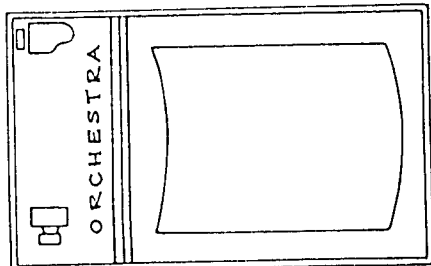

**K. CONCERT**  
Ample space is available in this arrangement for large musical instruments and a piano on the platform.

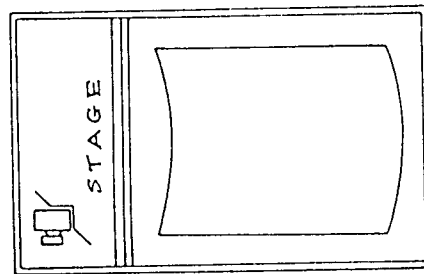

**L. DRAMA**  
The chancel platform serves as a stage for drama, interpretative dancing, church school pageants, etc. In this illustration, the organ console is screened from view.

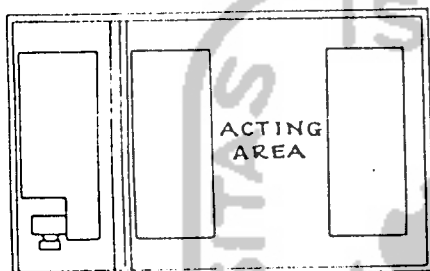

**M. DRAMA**  
The acting area is in the center of the nave and the chancel is used for seating. This is similar to theatre-in-the-round productions.

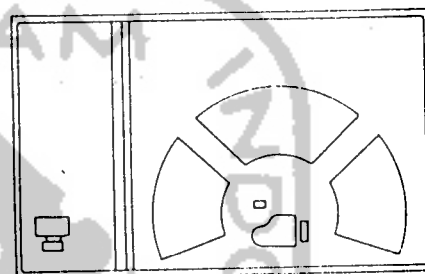

**N. GROUP SINGING**  
For community or groups singing the congregation is grouped around the piano and the song leader.

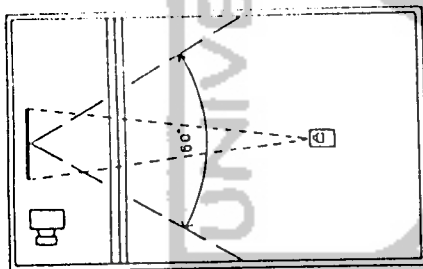

**O. AUDIO-VISUAL**  
The screen is located on the platform so that the majority of the audience would be within the recommended 60° viewing angle. Beyond this angle the picture becomes distorted.

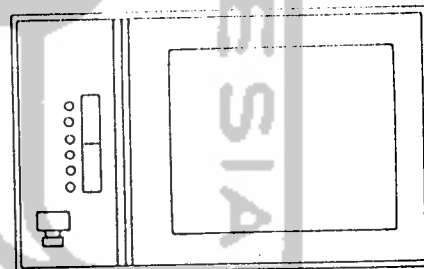

**P. MEETINGS**  
In this illustration two tables have been placed in the center of the platform with the leaders seated behind the tables. This could be used for debates, lectures or church or community meetings.

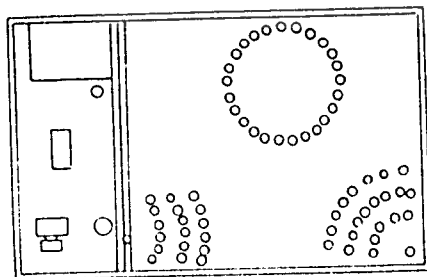

**Q. CHURCH SCHOOL**  
Three classes for youth or adults are shown in different parts of the room. We are assuming that separate classes would be provided for children.

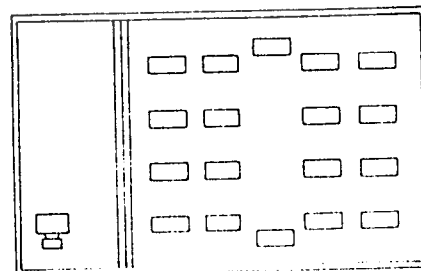

**R. STUDY HALL**  
The 40' x 65' room could also be used after school hours as a study hall. Separate tables are shown for each two to four students, as well as tables for those in charge.



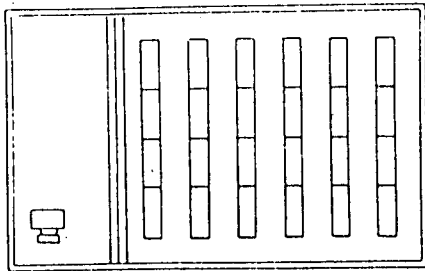

#### S. DINING

Using standard size tables (30" x 96") the room would accommodate 192 persons allowing 8 persons per table. The 15' x 40' platform could serve for the speaker's table, additional tables or for a program.

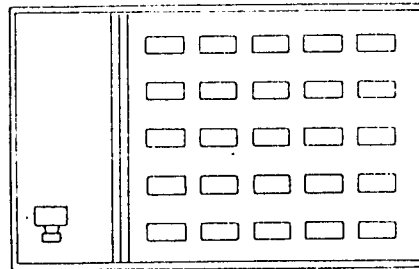

#### T. DINING

If smaller tables (30" x 72") were arranged with space between each table, the room would accommodate 150 persons allowing 6 persons per table. If the tables were moved together to provide space for 5 additional tables, the room would seat 180 persons.

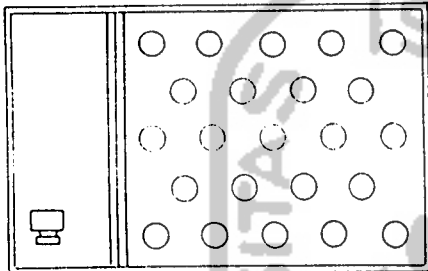

#### U. DINING

Round tables encourage a greater sense of fellowship since all persons are within conversation range of each other. This arrangement around 48" diameter tables seats 138 at 6 persons per table, or 184 at 8 persons per table.

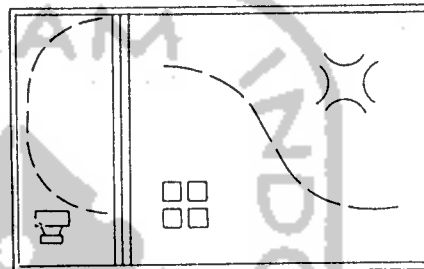

#### V. DISPLAYS

The room is arranged for such displays as paintings, sculpture, book exhibits, schools of mission displays, church school exhibits or any other type of exhibition which requires space for large numbers of people and ample viewing areas. The arrangement is planned to encourage the flow of traffic through the exhibitions.

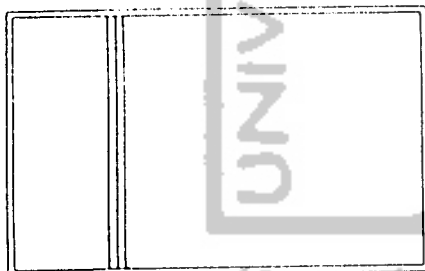

#### W. GROUP ACTIVITIES

If all the furniture in the rooms were movable, the entire area could be cleared for group activities. This would require ample nearby storage space for all furniture.

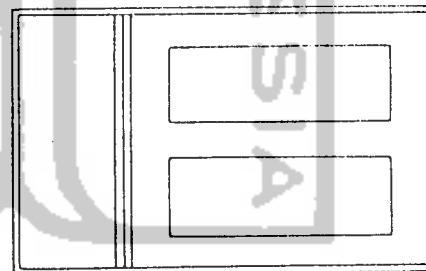

#### X. MINIMUM SEATING

The use of chairs allows the church to set up seats for the anticipated attendance. For each of these arrangements the room would appear to be full. (12 rows of chairs, 24" per person, 36" per row, seats 144).

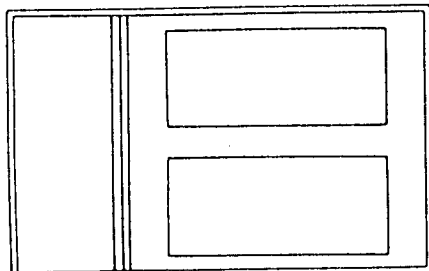

#### Y. AVERAGE SEATING

By reducing the spacing between chairs and between rows and by reducing the width of aisles, the room would seat 234 persons. (13 rows of chairs, 20" per person, 33" per row, seats 234).

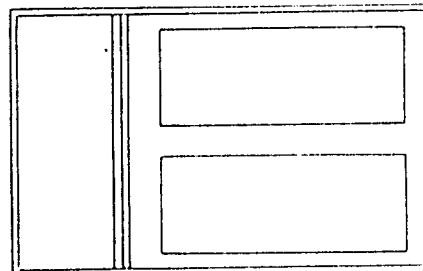

#### Z. MAXIMUM SEATING

For those occasions requiring maximum seating the chairs are placed closer together. This will still allow ample seating space for most individuals. (15 rows of chairs, 18" per person, 32" per row, seats 300).