

BAB IV HASIL RANCANGAN

4.1 Rancangan Kawasan Tapak

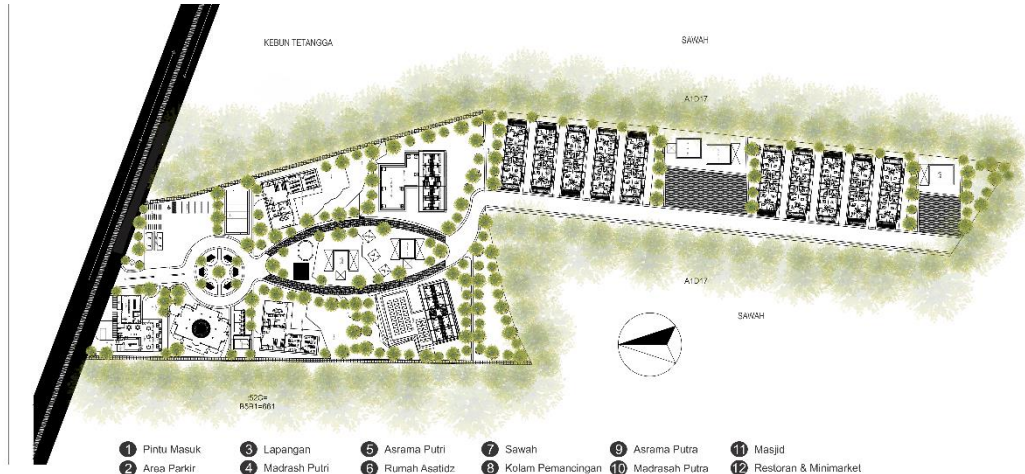

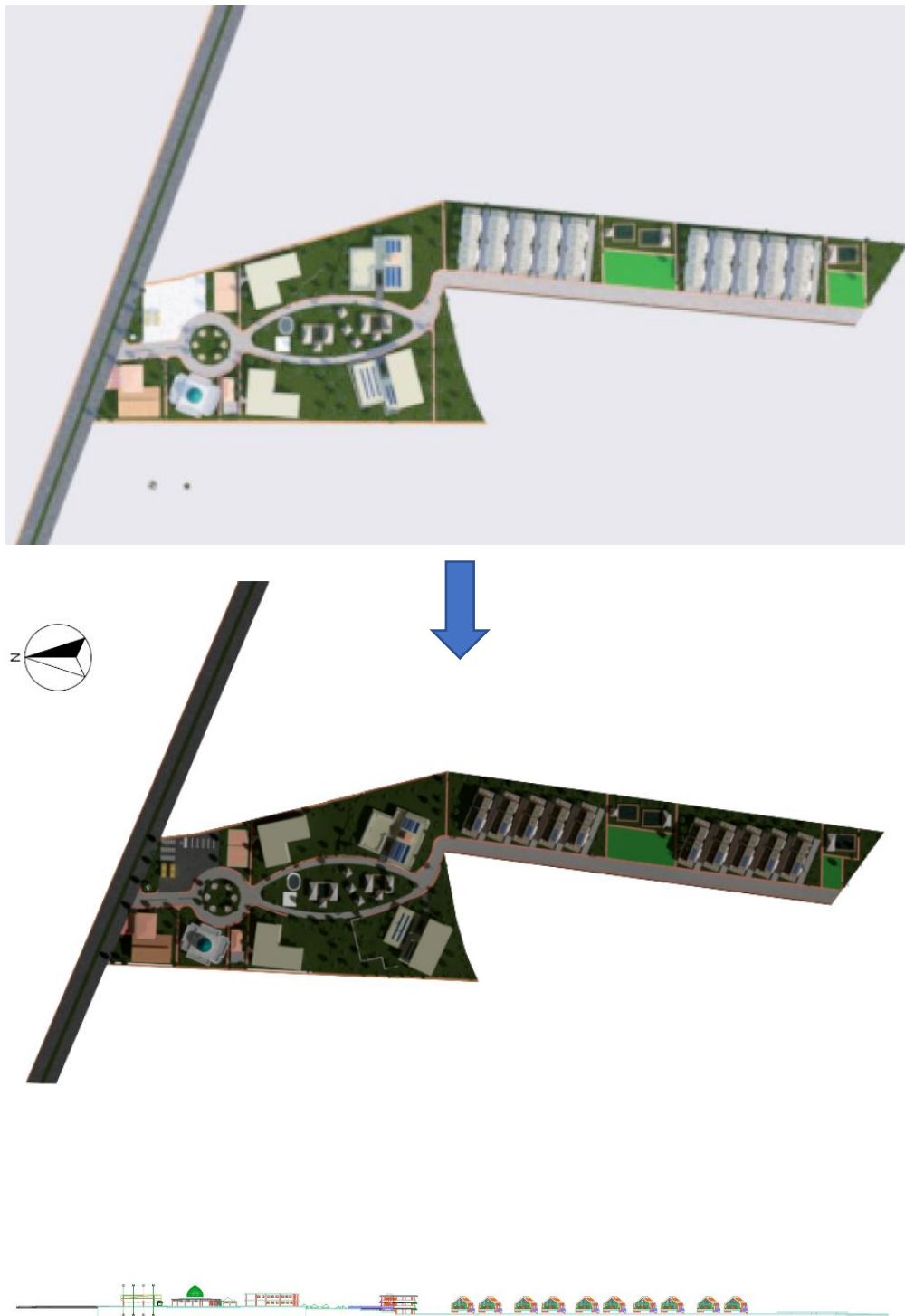

Gambar 4.1 Masterplan Before-After Revisi, Situasi Before-After Revisi dan Rencana Tapak Pondok Pesantren Subulana (dari atas ke bawah)
Sumber: Penulis (2019)

4.2 Rancangan Denah

Denah Asrama Santriwati lantai 1

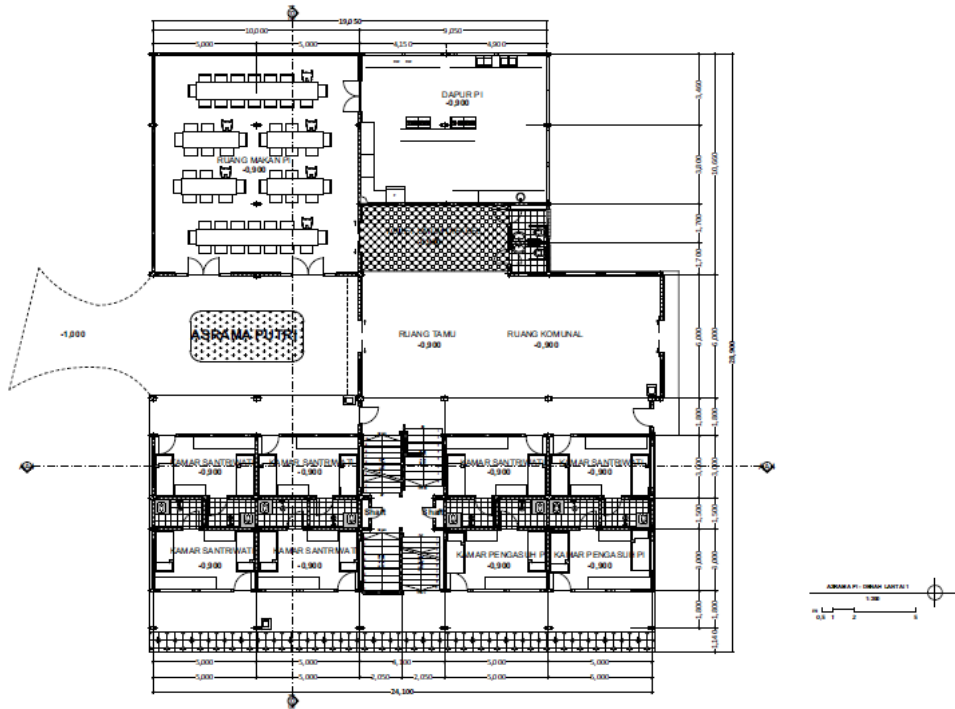

Denah Asrama Santriwati lantai 2

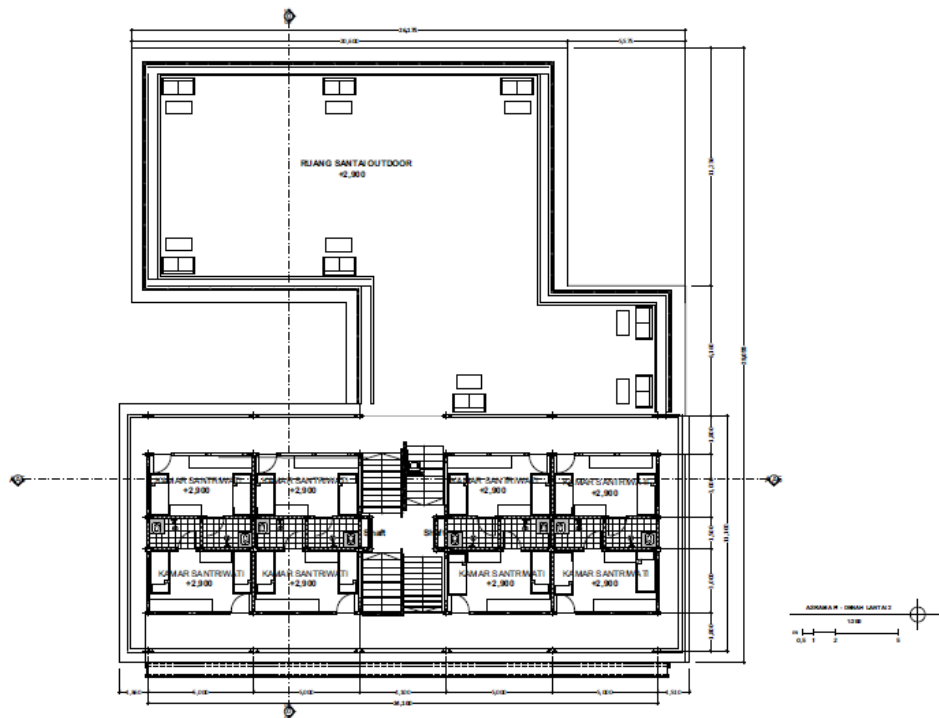

Gambar 4.2 Denah Asrama Santriwati Lantai 1 dan Lantai 2 (Atas ke bawah)
Sumber: Penulis (2019)

Denah Asrama Santriwan lantai 1

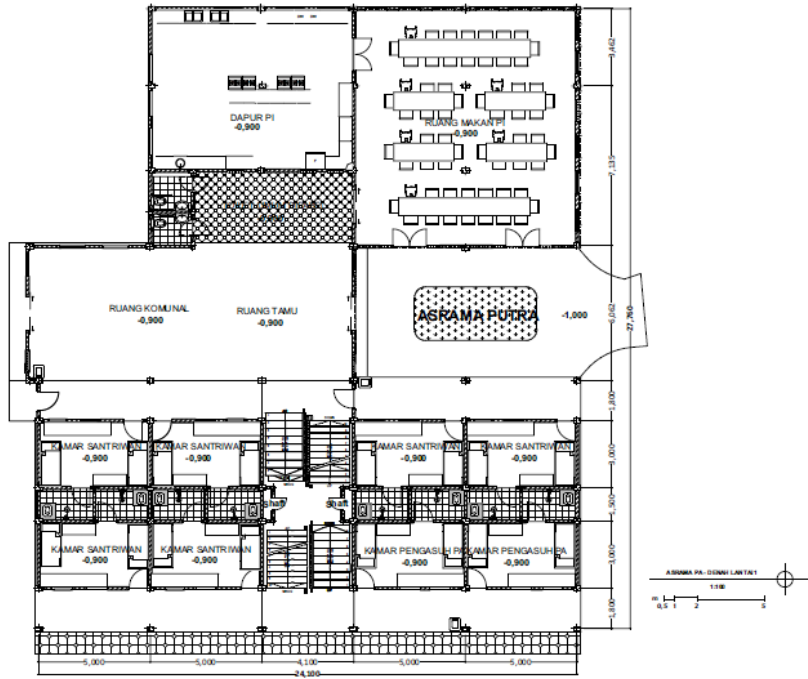

Denah Asrama Santriwan lantai 2

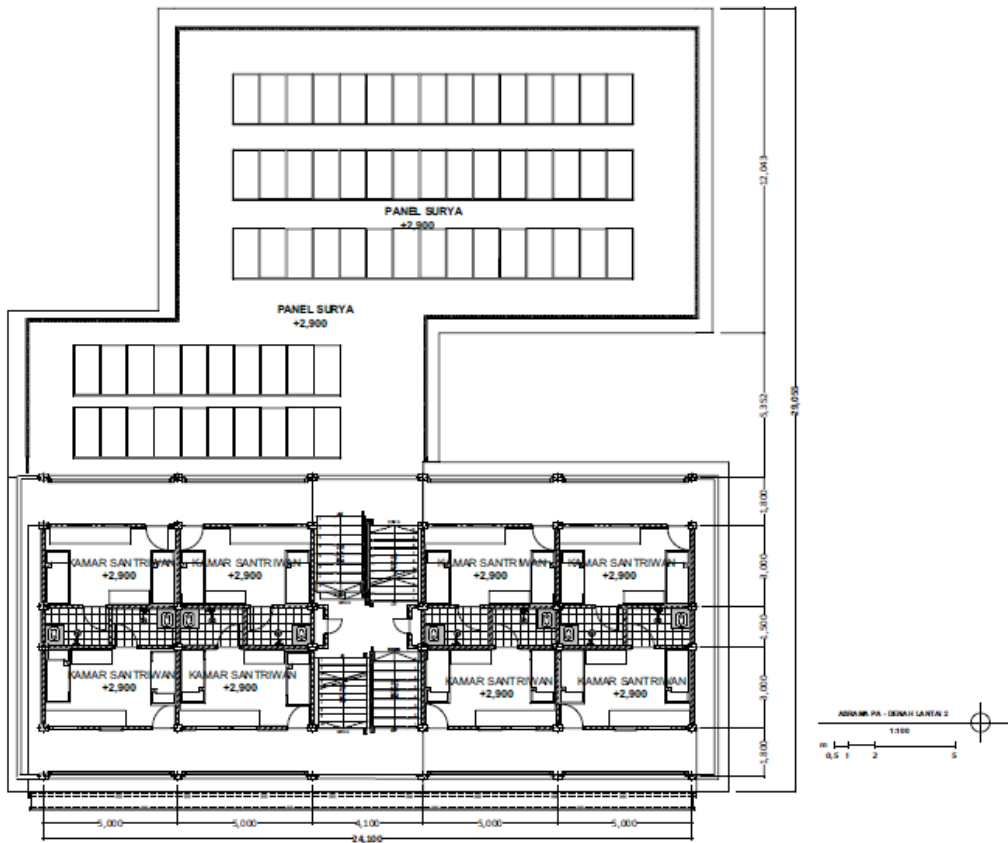

Denah Asrama Santriwan lantai 3

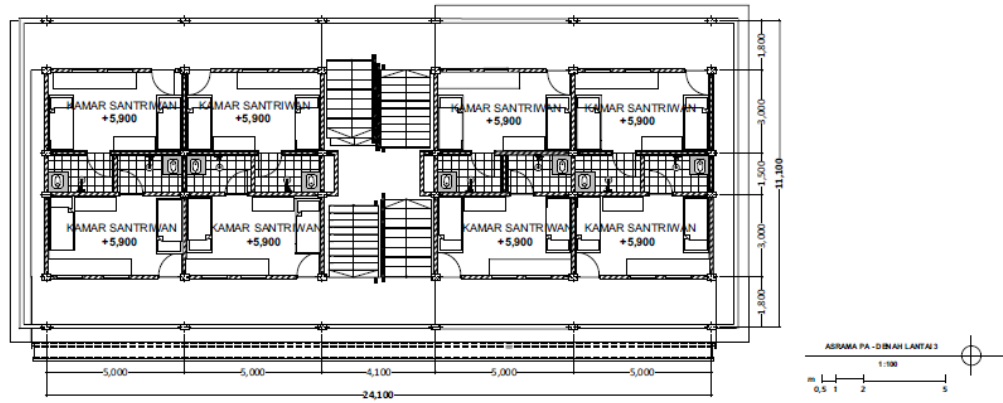

Gambar 4.3 Denah Asrama Santriwan Lantai 1, Lantai 2 dan Lantai 3 (Atas ke bawah)
 Sumber: Penulis (2019)

Denah Rumah Asatidz

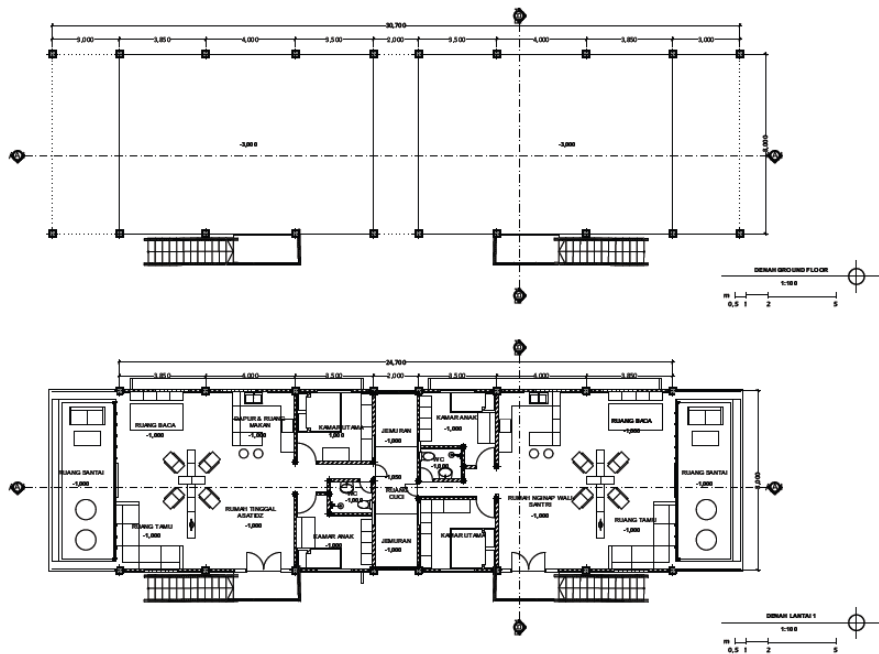

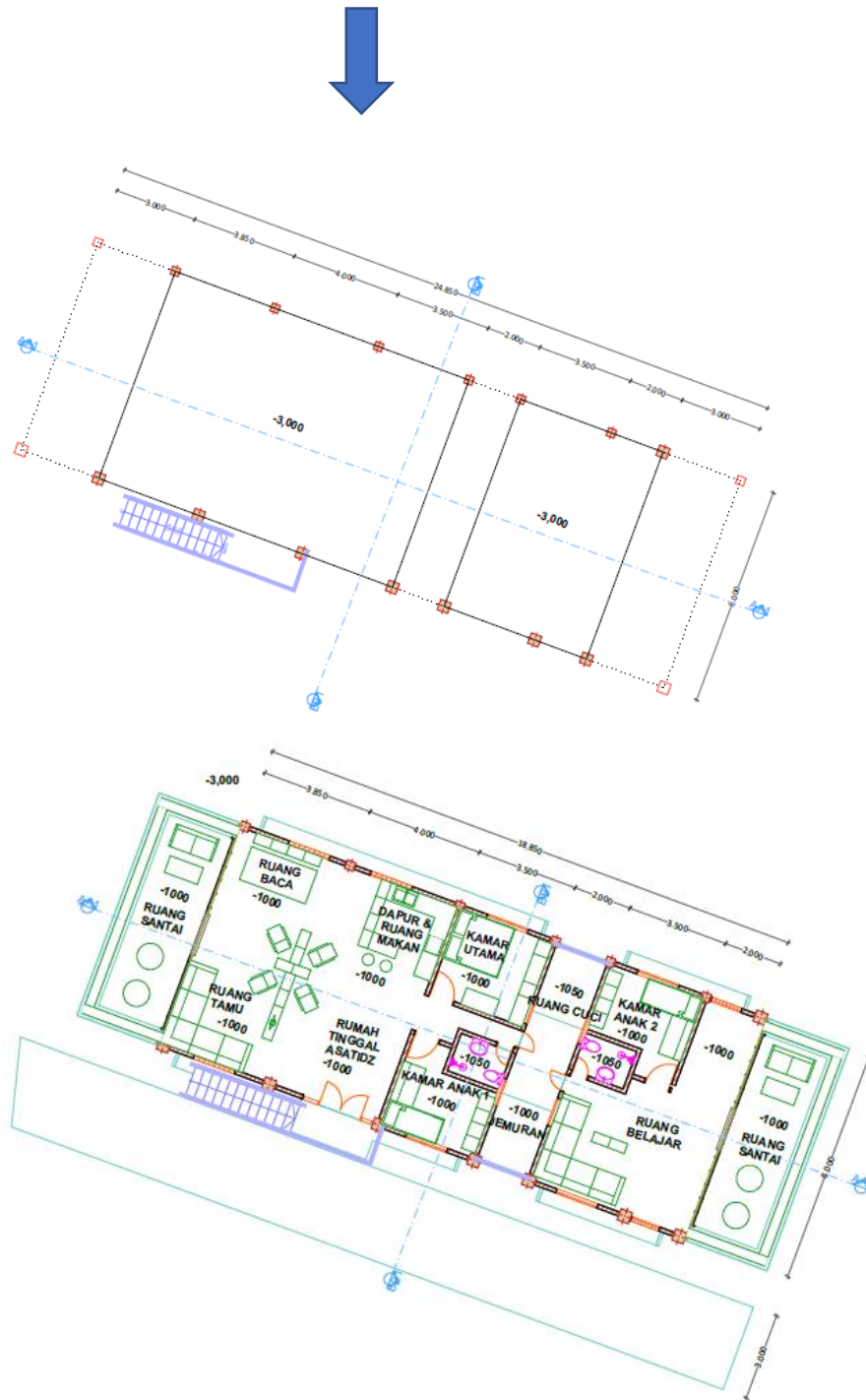

Gambar 4.4 Denah Rumah Asatidz Before-After Revisi Lantai *Ground Floor* dan Lantai 1
(Atas ke bawah)
Sumber: Penulis (2019)

Denah Madrasah

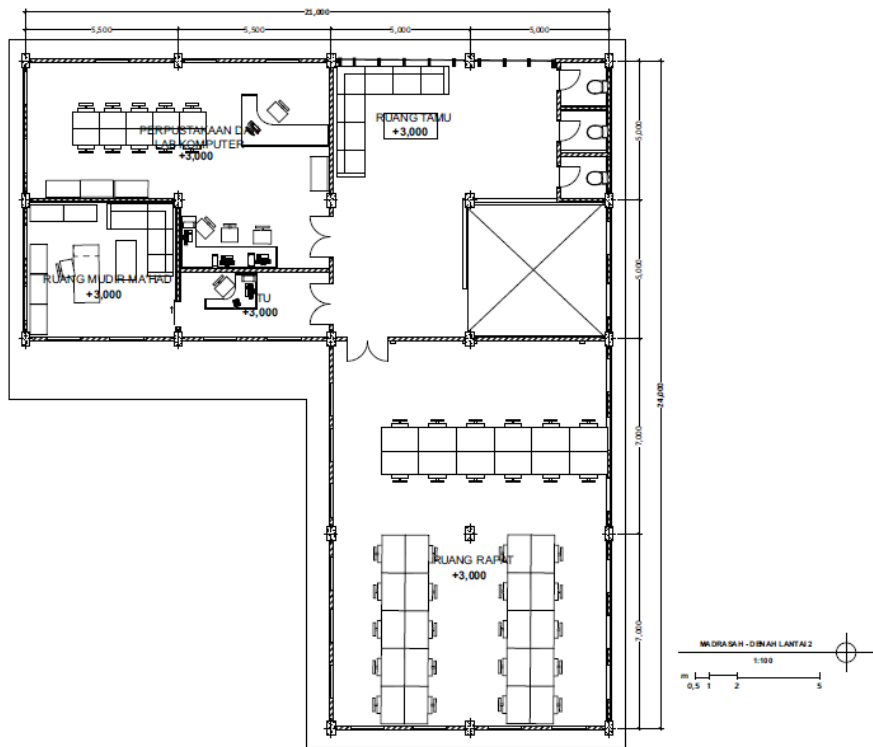
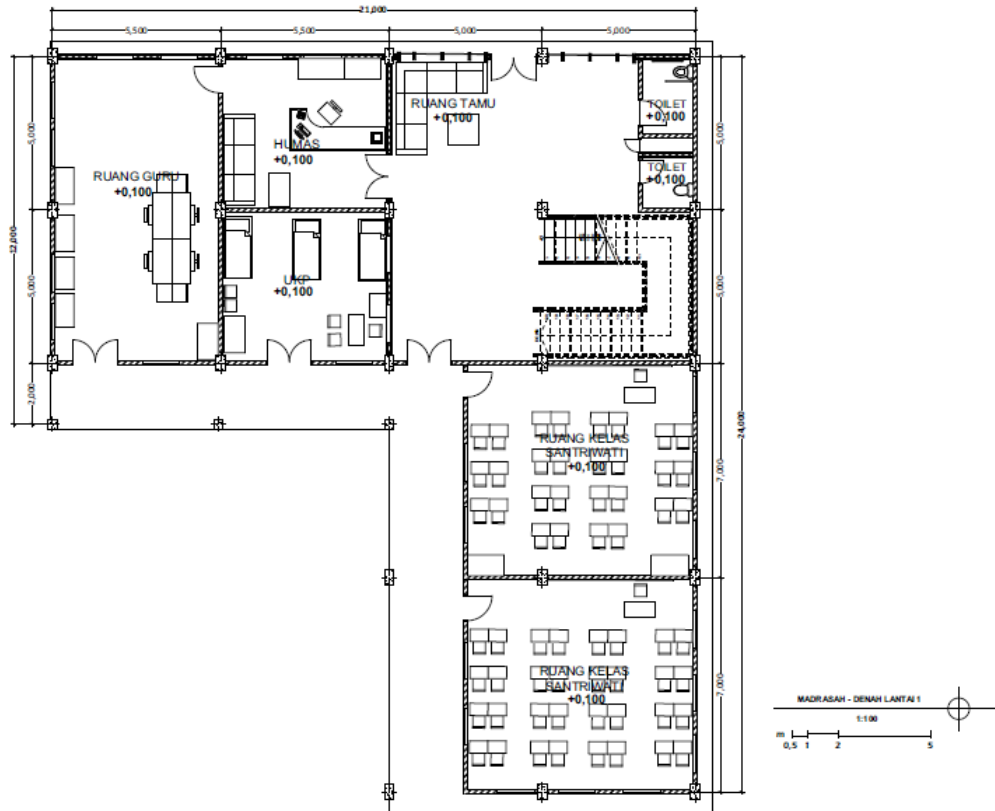

4.3 Rancangan Selubung Bangunan

Tampak Asrama Santriwati

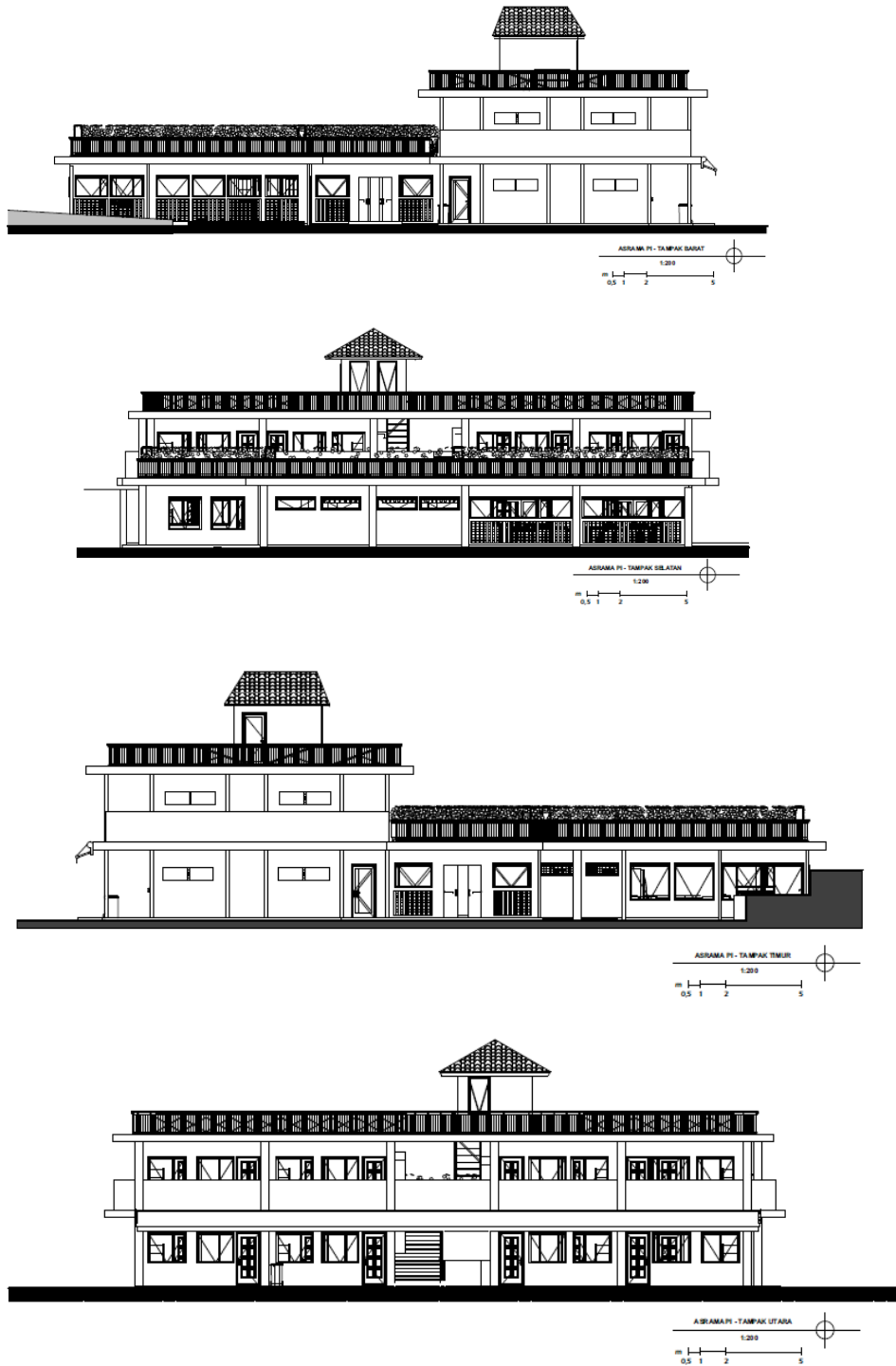

Gambar 4.8 Tampak Barat, Utara, Timur dan Selatan Asrama Santriwati (Atas ke bawah)

Sumber: Penulis (2019)

Tampak Asrama Santriwan

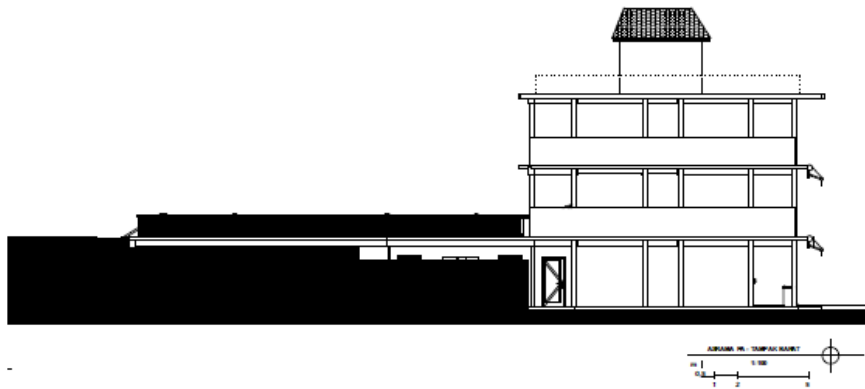
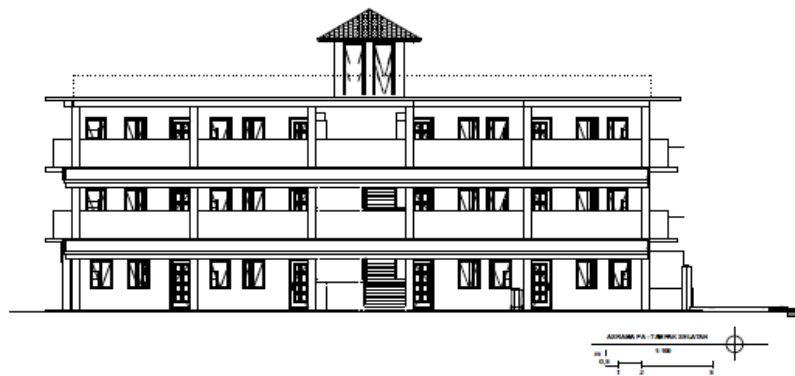
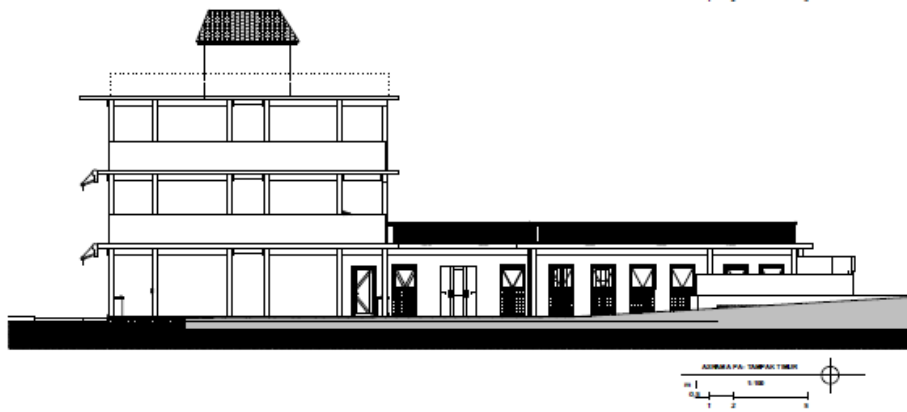
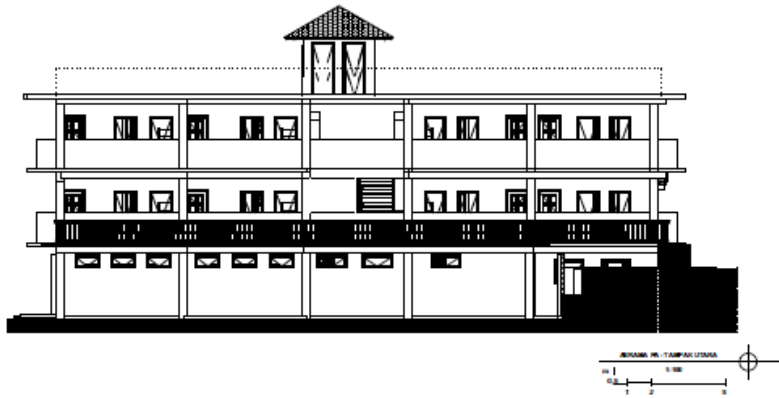

Gambar 4.9 Tampak Selatan, Timur, Utara dan Barat Asrama Santriwan (Atas ke bawah)
Sumber: Penulis (2019)

Tampak Rumah Asatidz

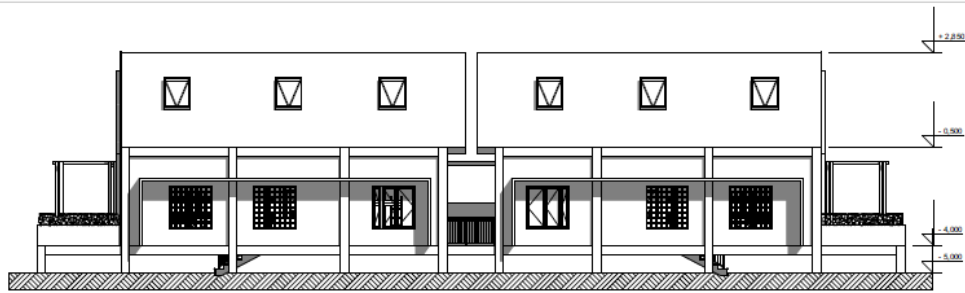

⊙ Tampak Samping R. Asatidz
Skala 1 : 100

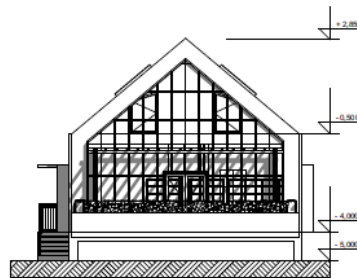

⊙ Tampak Belakang R. Asatidz
Skala 1 : 100

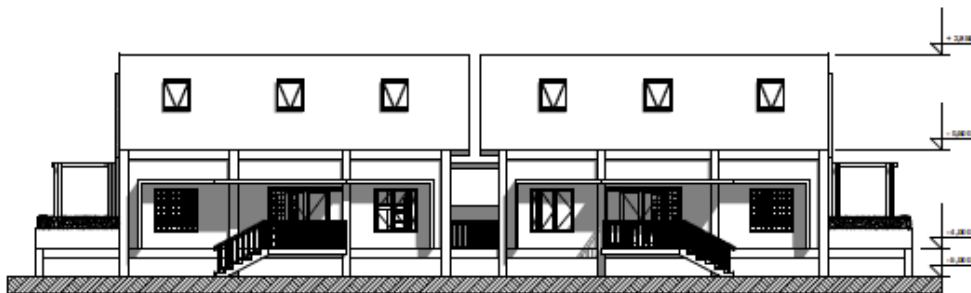

⊙ Tampak Samping R. Asatidz
Skala 1 : 100

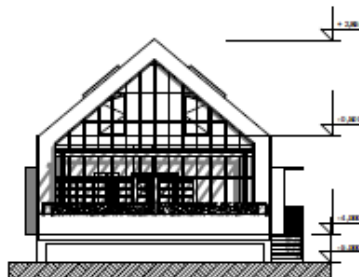

⊙ Tampak Depan R. Asatidz
Skala 1 : 100



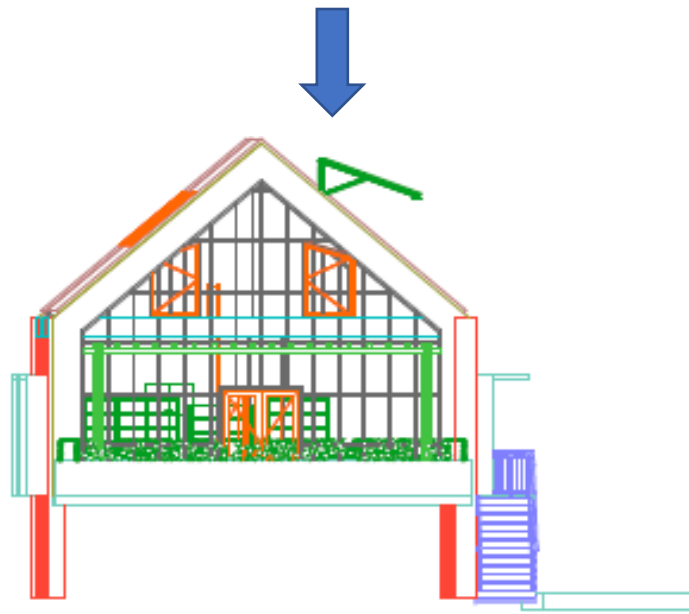

Tampak Depan R. Asatidz Elevation

1:100

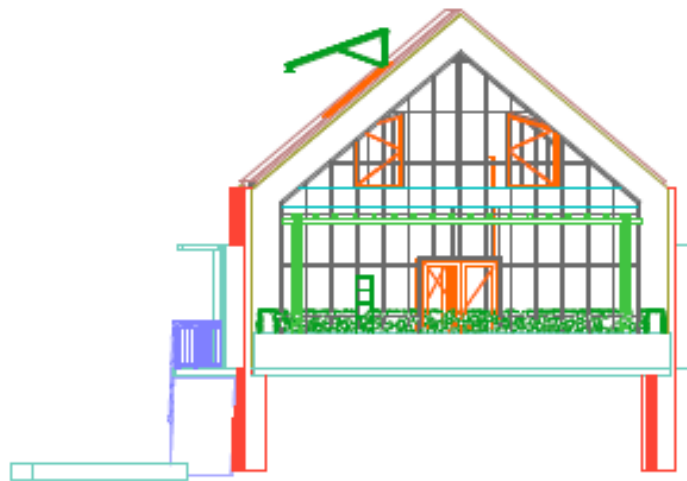

Tampak Belakang R. Asatidz Elevation

1:100

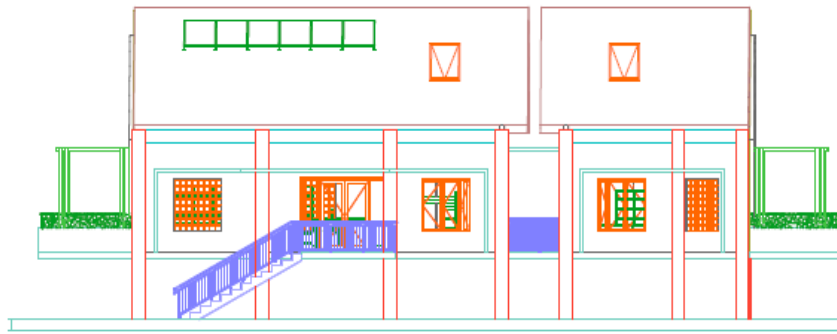

Tampak Samping Kanan R. Asatidz

Elevation

1:100

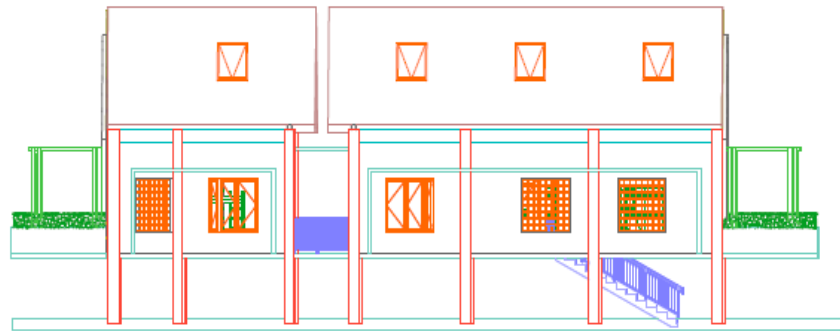

Tampak Samping Kiri R. Asatidz

Elevation

1:100

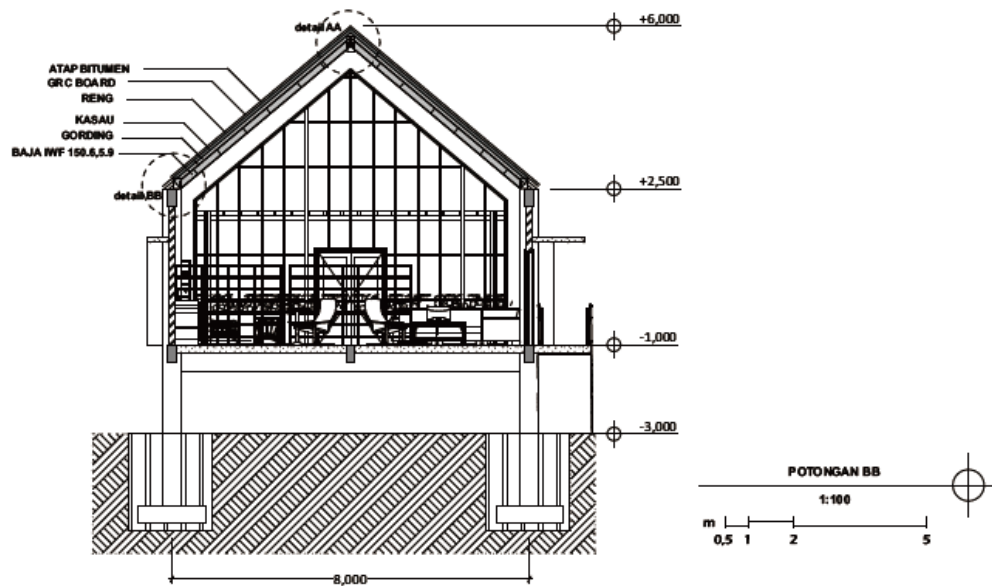

DETAIL AA

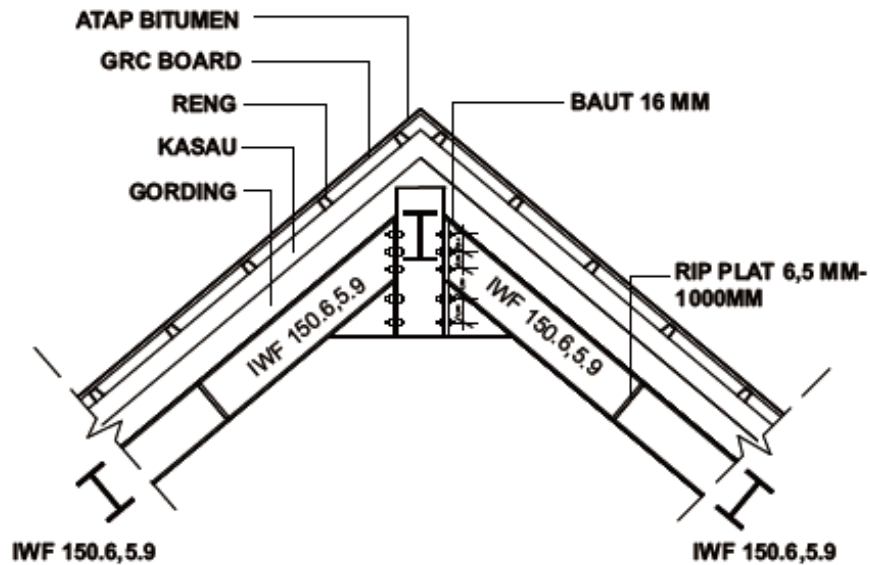

DETAIL BB

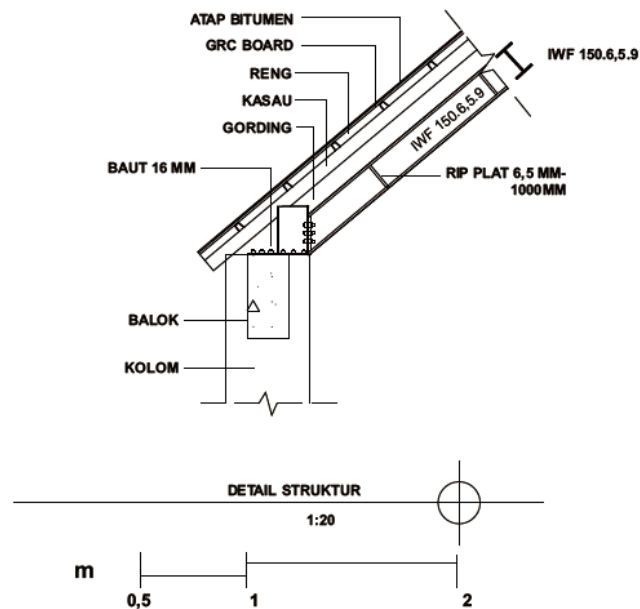

Gambar 4.10 Tampak Samping Kiri, Tampak Samping Kanan, Tampak Belakang, Tampak Depan (Before-After Revisi), Detail Selubung Bangunan Sesuai Tema Detail Rangka Atap Rumah Asatidz (Atas ke Bawah)

Sumber: Penulis (2019)

Detail selubung bangunan sesuai tema pada rumah asatidz yakni pada rangka atap yang menggunakan material baja ramah lingkungan dan memiliki ventilasi pada atap untuk udara ruangan yang nyaman.

Tampak Madrasah

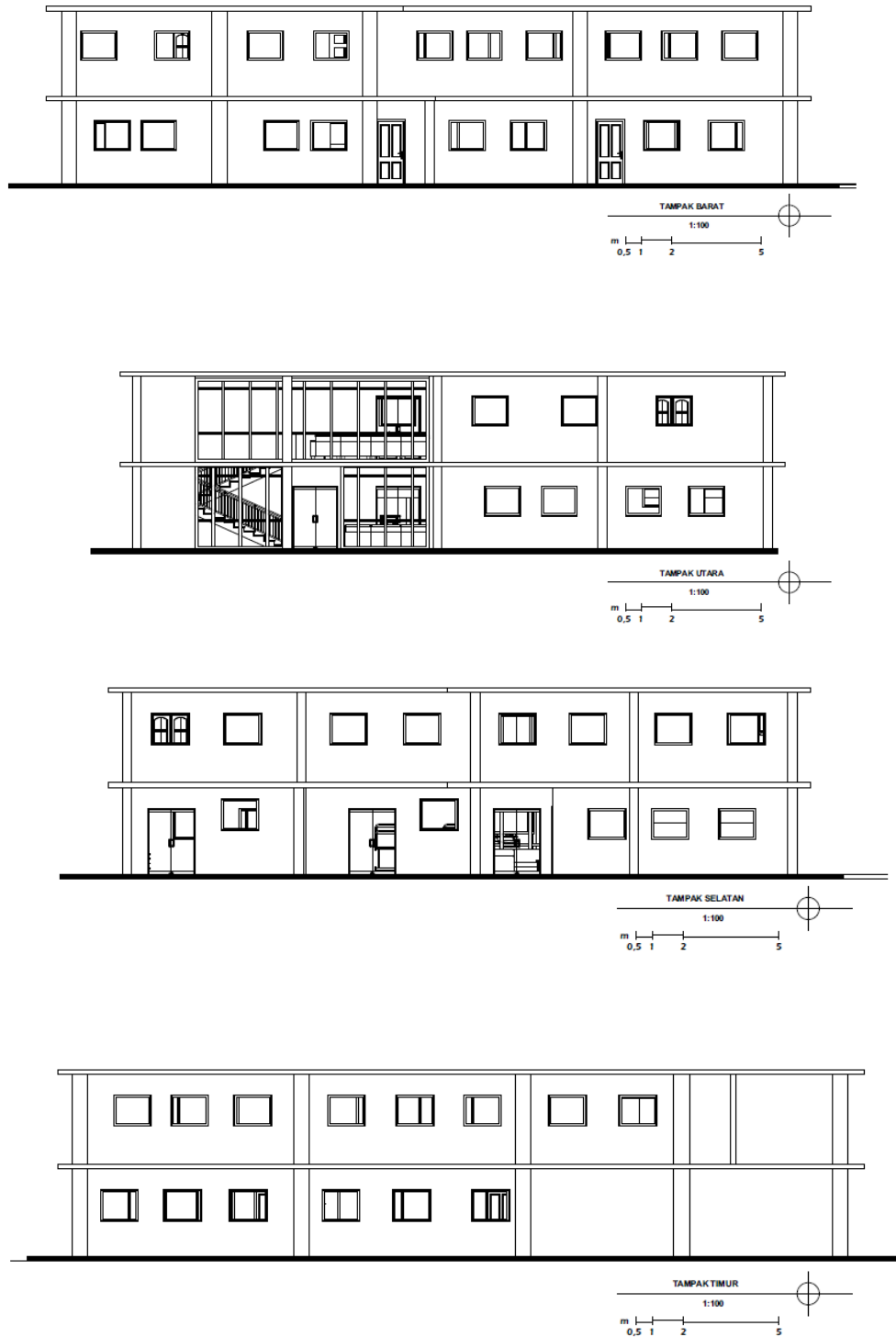

Gambar 4.11 Tampak Utara, Tampak Barat, Tampak Selatan dan Tampak Timur Rumah Asatidz

Sumber: Penulis (2019)

Tampak Masjid

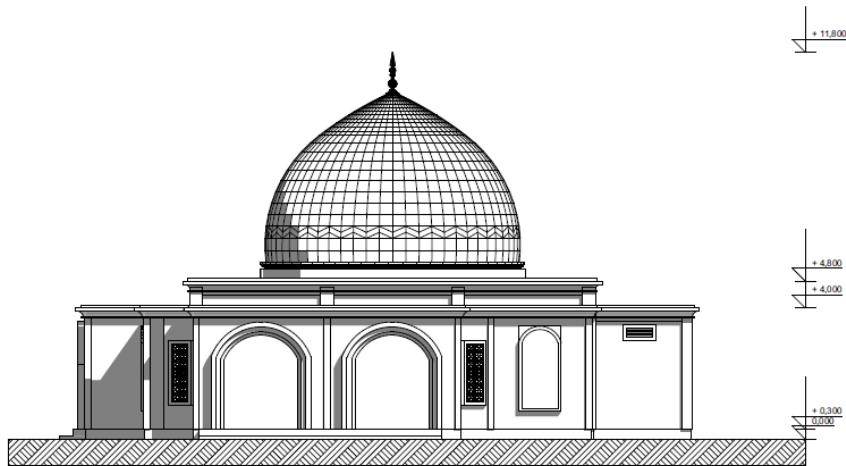
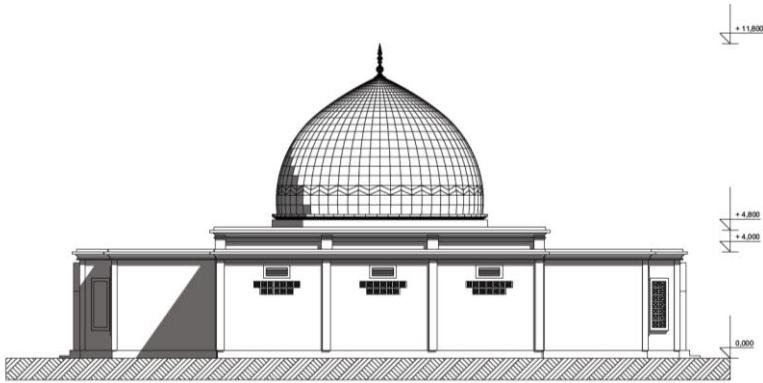
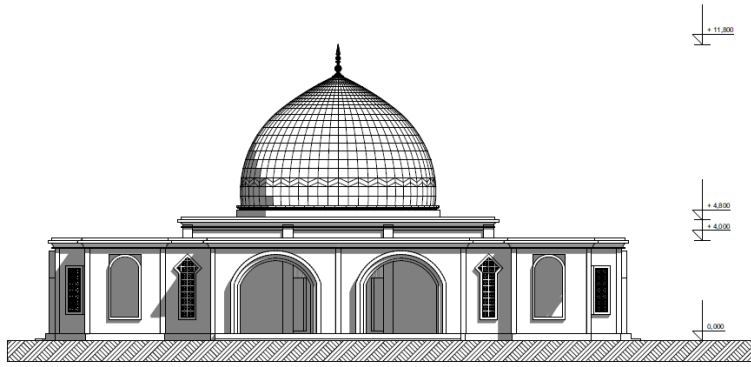

○ Tampak Samping Masjid
Skala 1 : 100

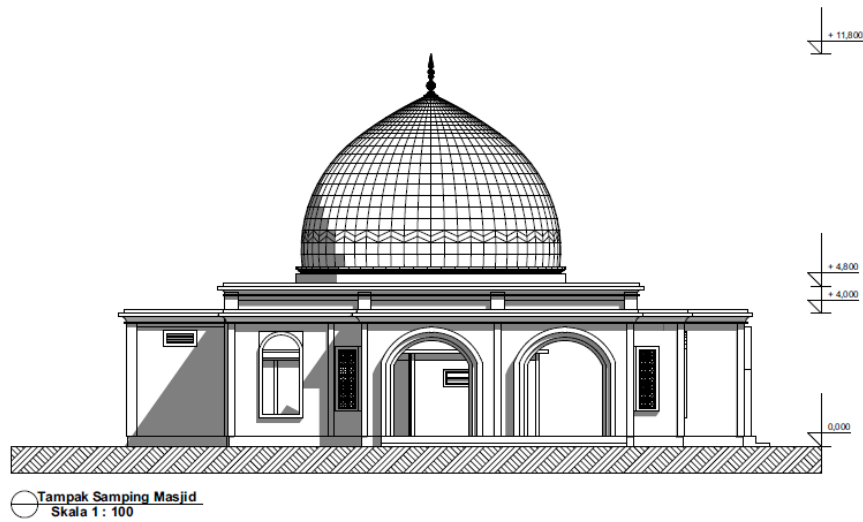

Gambar 4.12 Tampak Depan, Tampak Belakang, Tampak Samping Kanan dan Tampak Samping Kiri Masjid
 Sumber: Penulis (2019)

Tampak Restoran dan Minimarket

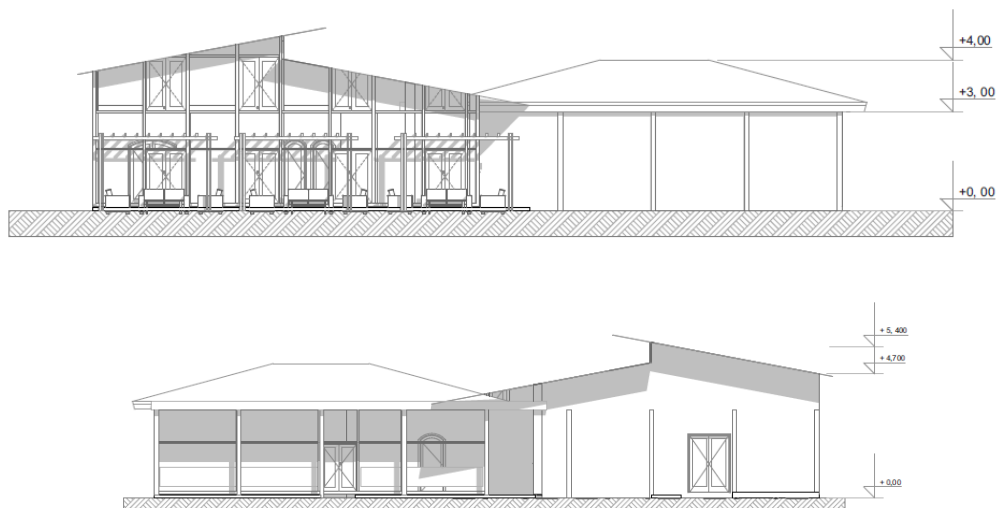

Gambar 4.13 Tampak Utara dan Tampak Selatan Restoran dan Minimarket
 Sumber: Penulis (2019)

4.4 Rancangan Sistem Struktur

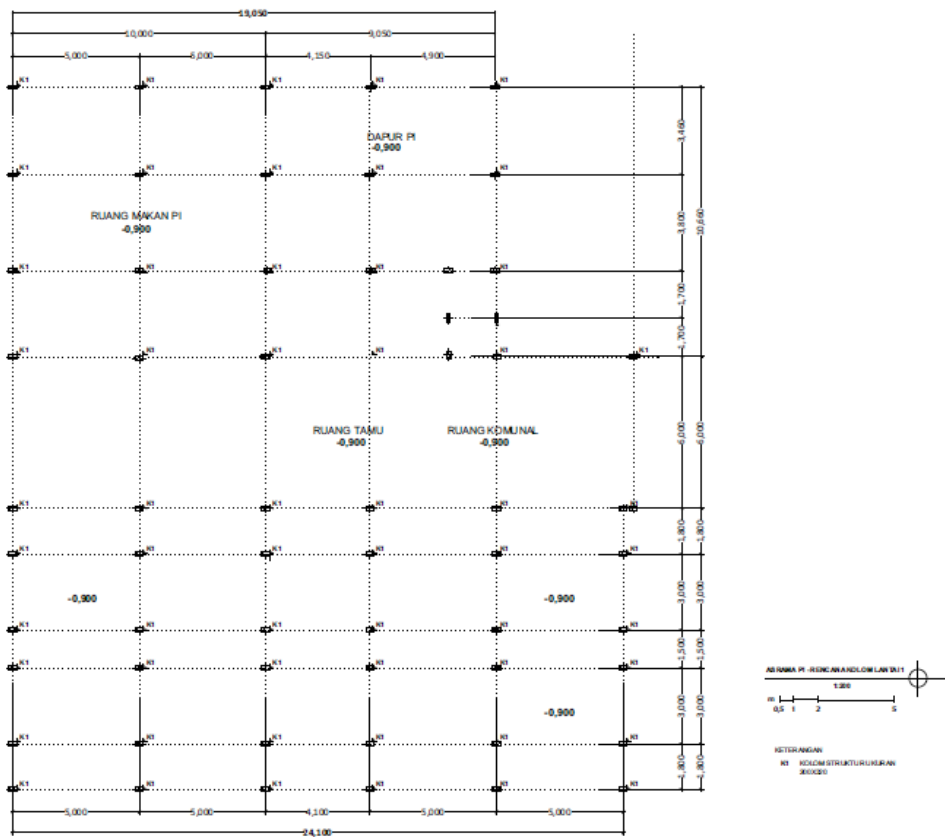
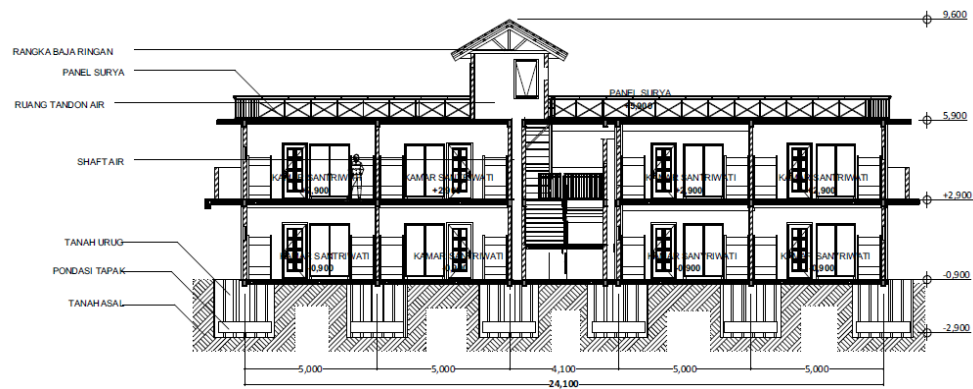
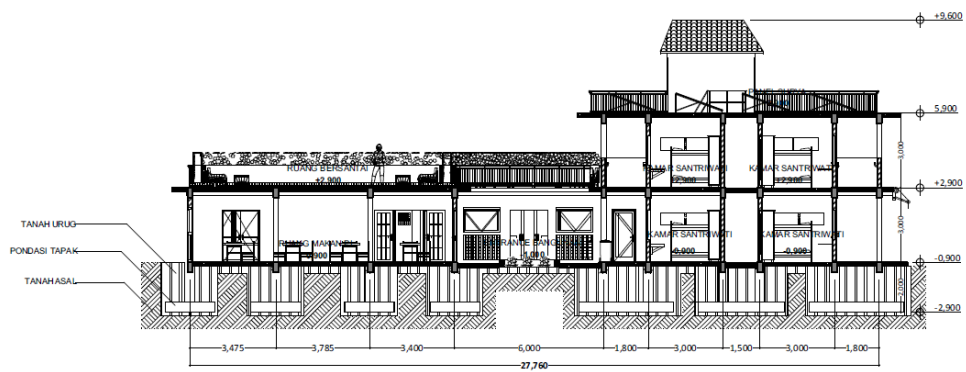

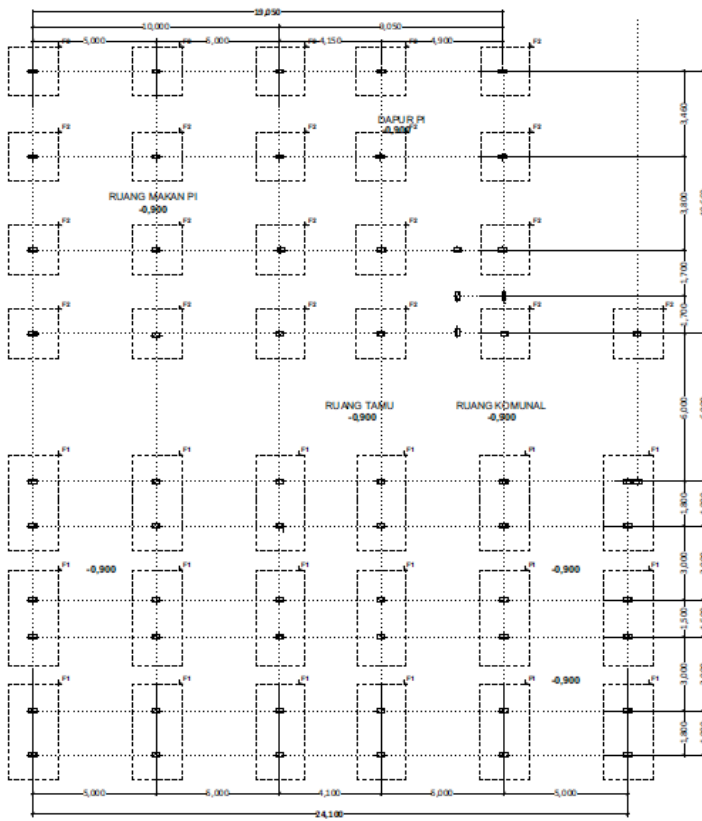
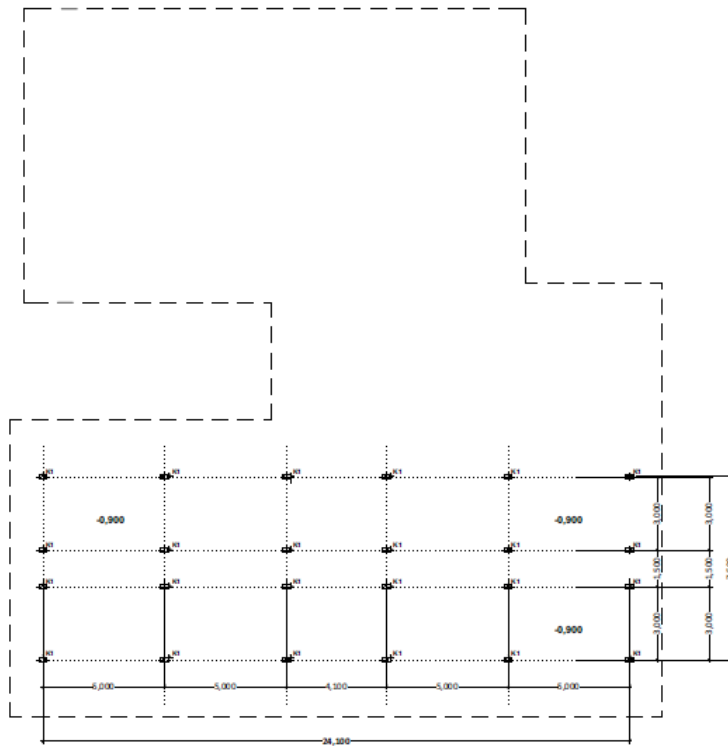

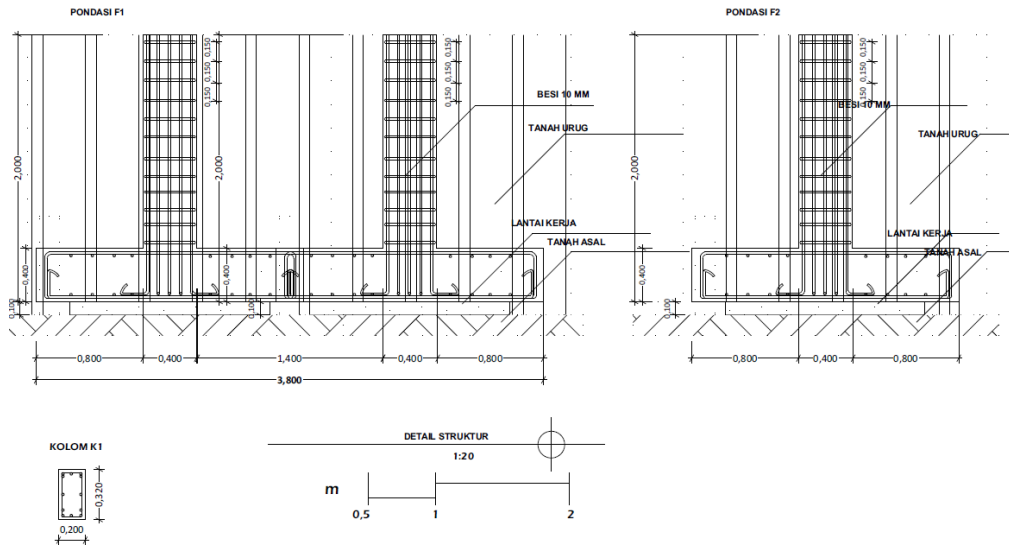

Gambar 4.14 Rancangan Sistem Struktur Potongan, Rencana Kolom Balok Asrama Santriwati dengan Pondasi Footplate.
 Sumber: Penulis (2019)

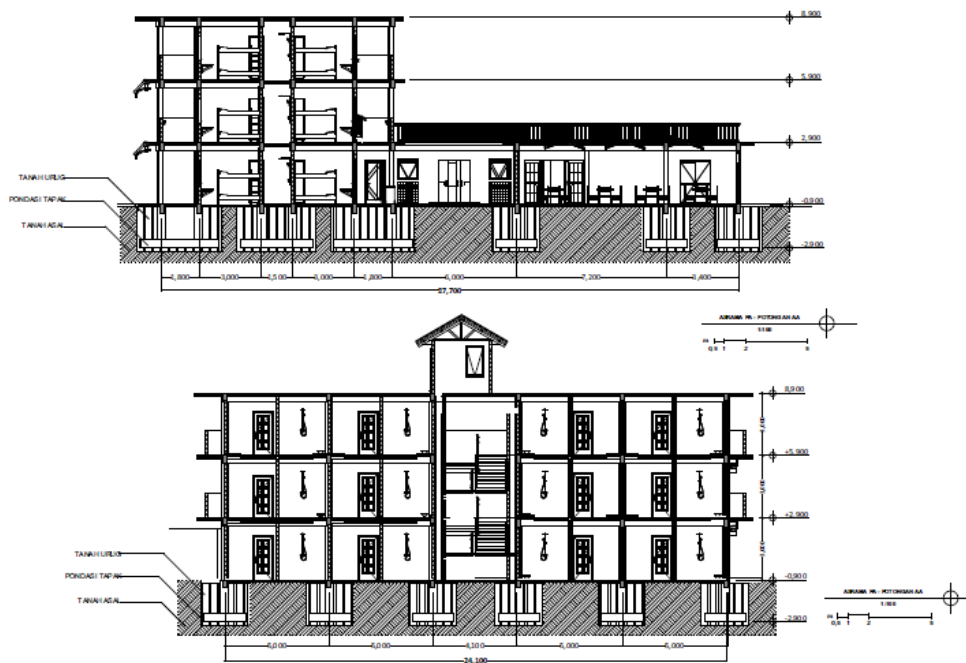

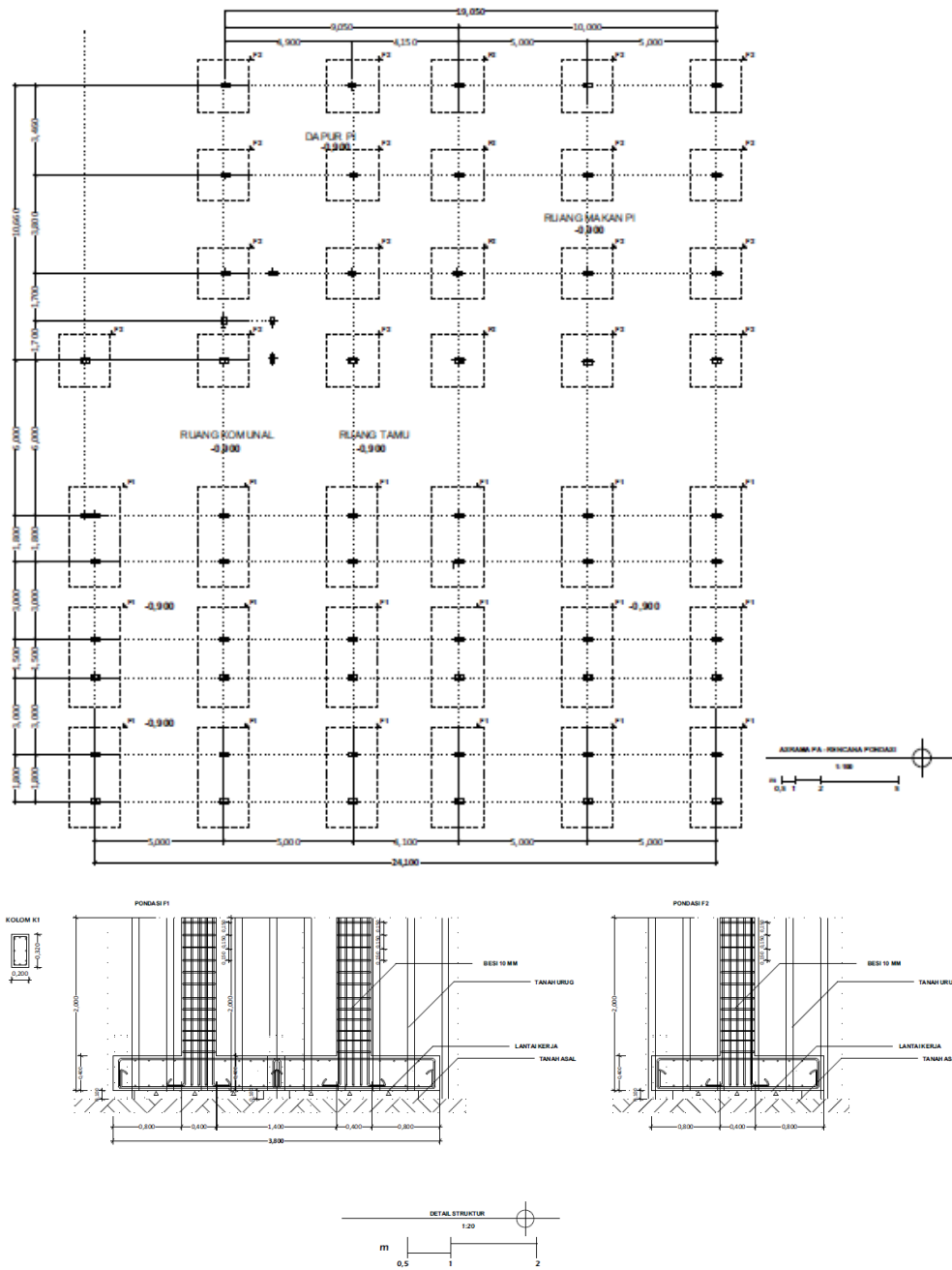

Gambar 4.15 Rancangan Sistem Struktur Asrama Santriwan dengan Pondasi Footplate.
 Sumber: Penulis (2019)

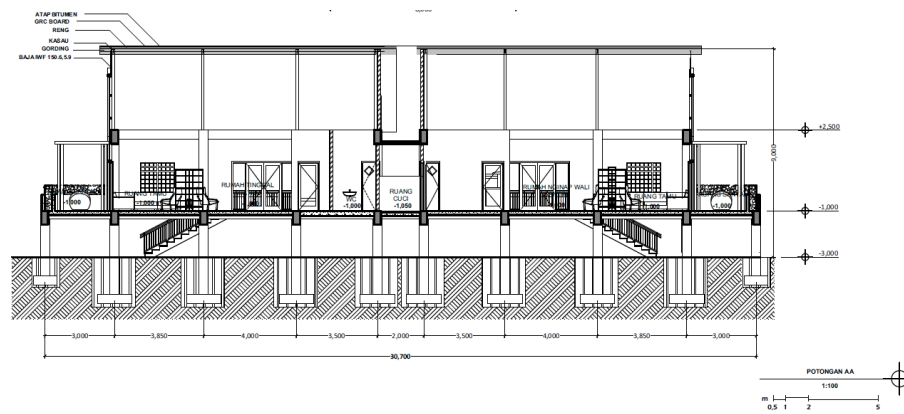
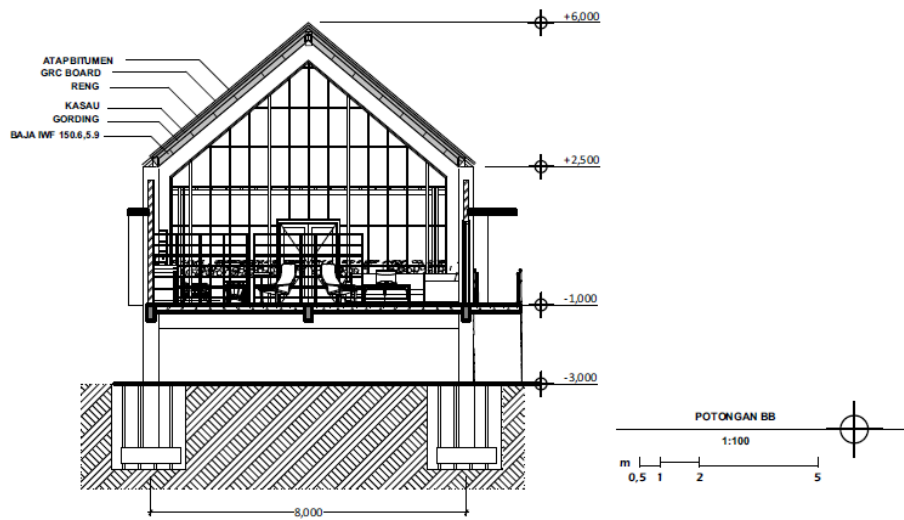

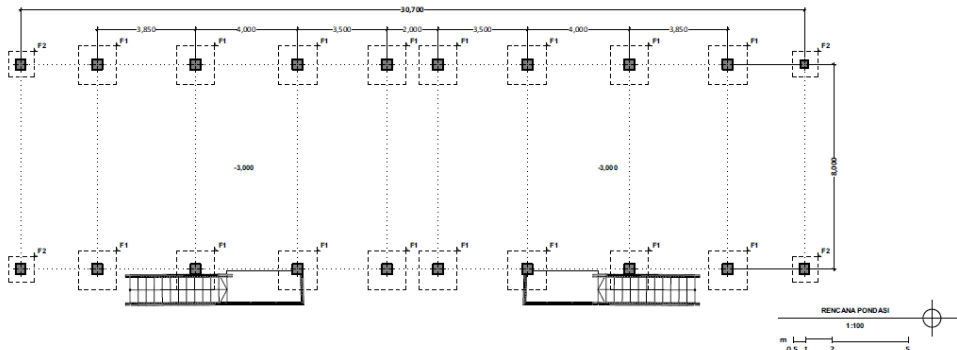
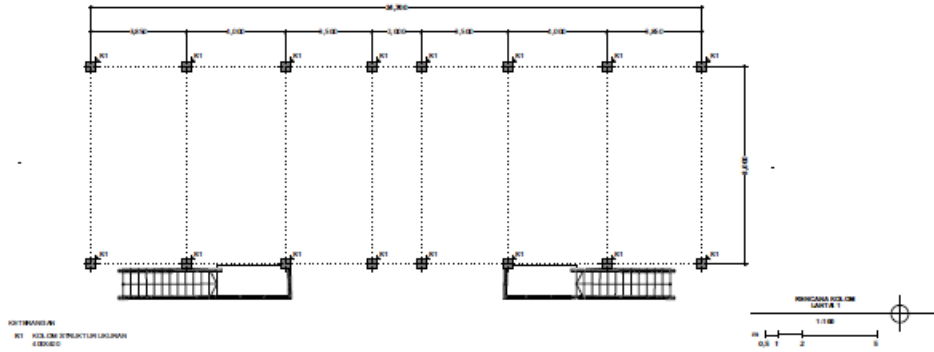
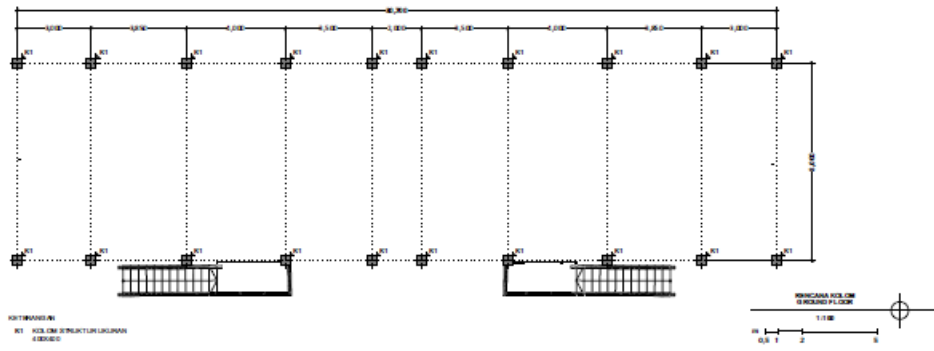

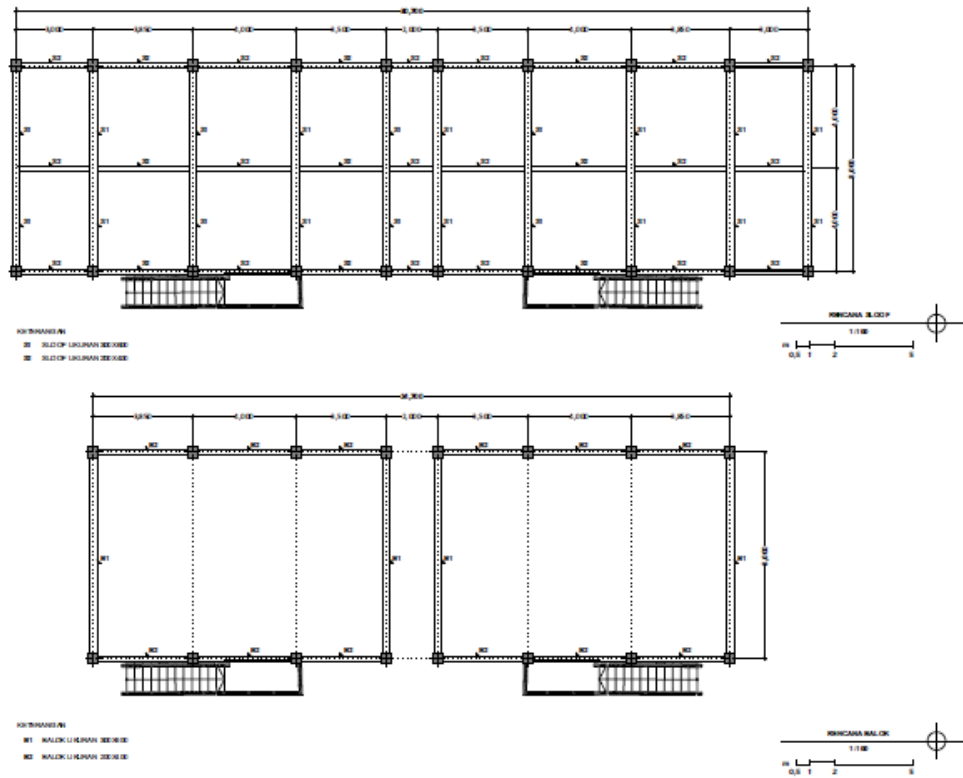

Gambar 4.16 Rancangan Sistem Struktur Potongan, Rencana Kolom Balok Sloof Rumah Asatidz dengan Pondasi Footplate.
 Sumber: Penulis (2019)

4.5 Rancangan Sistem Utilitas



Gambar 4.17 Rancangan Sistem Utilitas Pongpes Subulana.
 Sumber: Penulis (2019)

4.6 Rancangan Sistem Akses Disabilitas

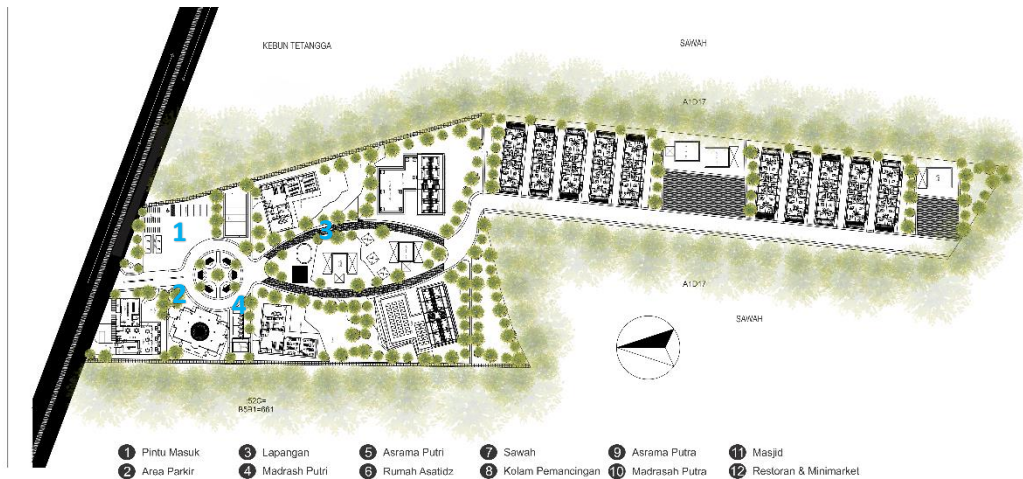

1 Parkir Khusus



1. Akses disabilitas berupa jalan masuk dan parkir khusus disabilitas.
2. Akses disabilitas menuju fasilitas-fasilitas ponpes dengan area *dropoff* seperti masjid, sekolah, restoran dan minimarket, serta lapangan olahraga.

2 Akses *dropoff* untuk disabilitas



3. Akses jalan disabilitas berupa ram menuju fasilitas-fasilitas ponpes.

3 Akses disabilitas berupa ram



4. Fasilitas toilet khusus disabilitas, berada di selatan masjid ponpes satu ruang dengan tempat whudu masjid.



4.7 Rancangan Sistem Keselamatan Bangunan



Titik kumpul saat *emergency* terdapat pada tempat parkir ponpes.



Selain itu terdapat APAR yang diletakkan di dalam bangunan untuk keselamatan kebakaran bangunan ponpes.

Gambar 4.18 Rancangan Sistem Akses Disabilitas.

Sumber: Penulis (2019)

4.8 Detail Penyelesaian Interior Sesuai Tema

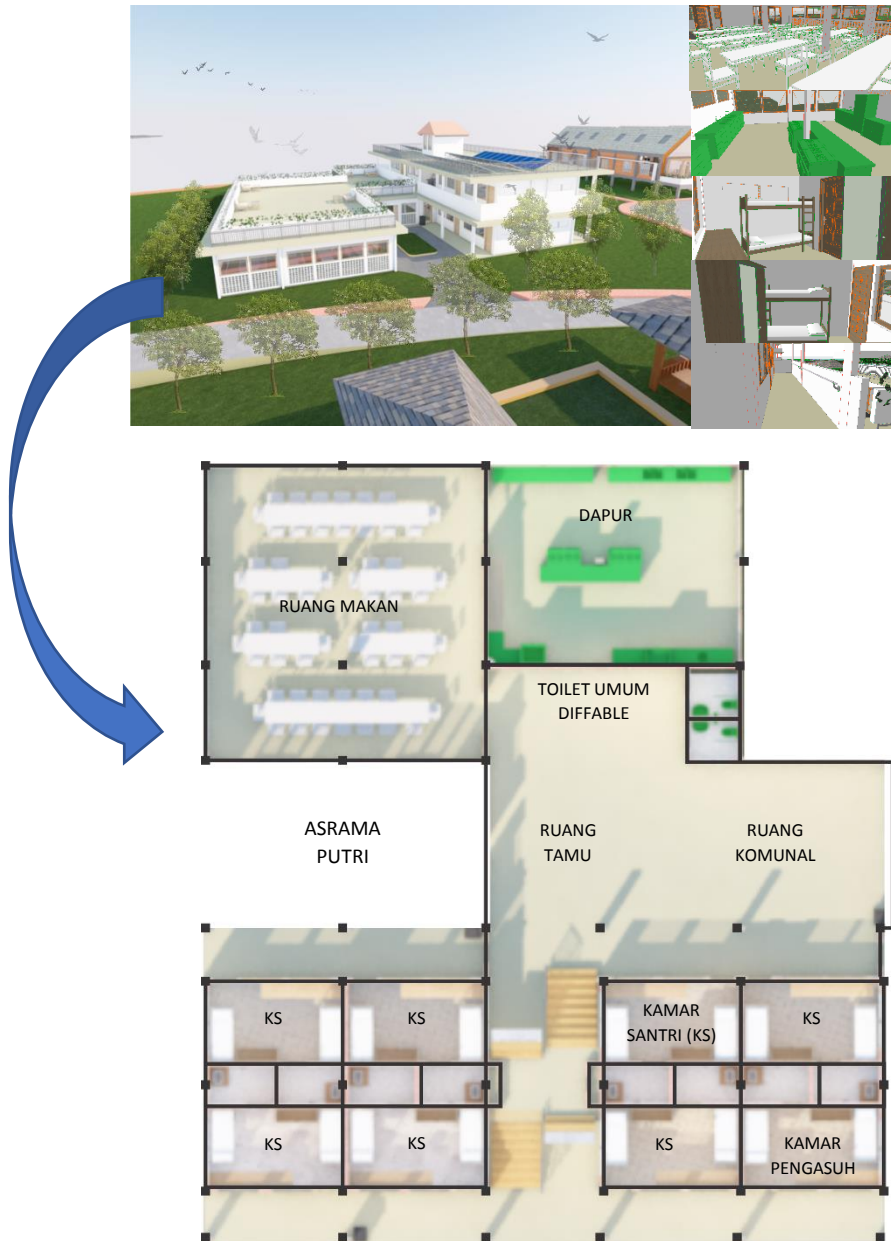

Gambar 4.19 Detail Penyelesaian Interior Asrama Santriwati.
Sumber: Penulis (2019)

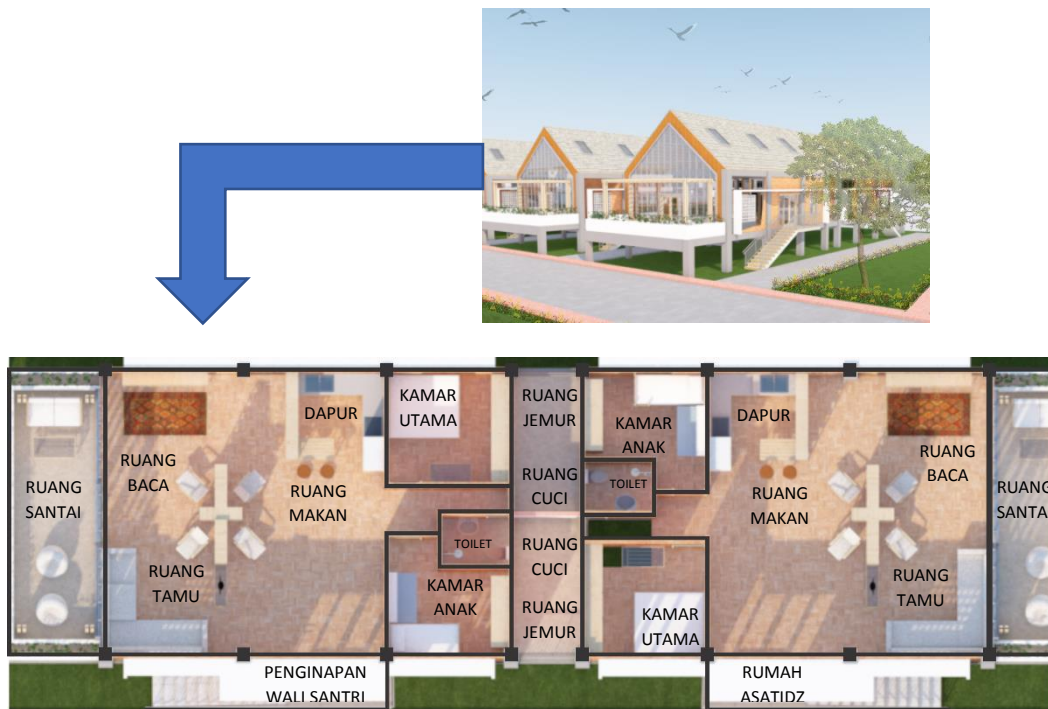

Gambar 4.20 Detail Penyelesaian Interior Rumah Asatidz.
Sumber: Penulis (2019)

4.9 Rancangan Detail Arsitektural Khusus

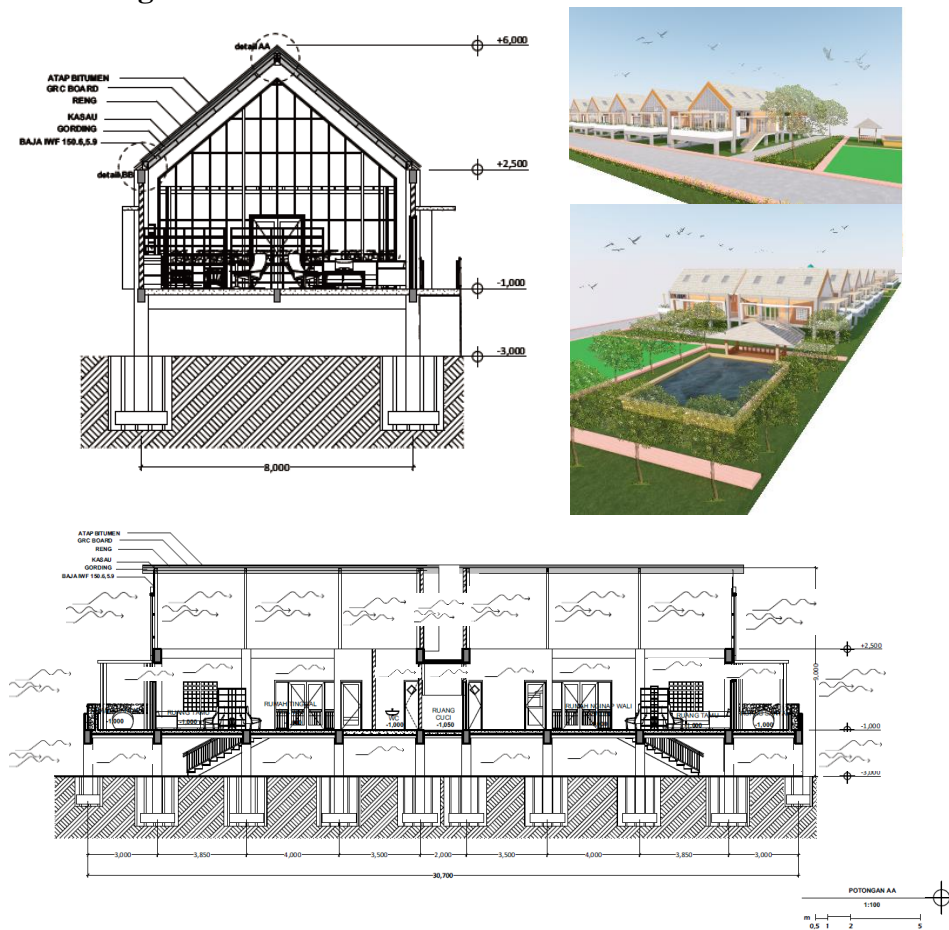

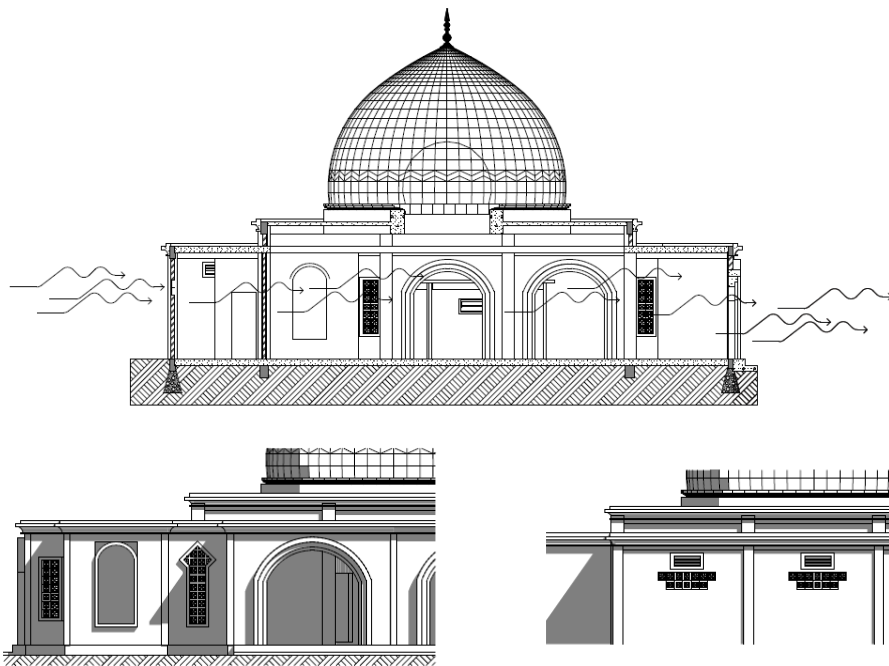

Gambar 4.22 Rancangan Detail Arsitektural Khusus, Skema Penghawaan Alami Masjid.
 Sumber: Penulis (2019)

Orientasi bangunan masjid mengarah ke arah datangnya angin. Sehingga dapat mengoptimalkan masuknya angin ke dalam ruang masjid.

Roster dan juga jendela kosong berbentuk ARCH pada gambar sebelah kiri selain sebagai ornamen arsitektural juga sebagai bukaan untuk keluar masuknya udara. Kemudian roster dan ventilasi kisi-kisi berbentuk ARCH pada gambar sebelah kanan selain sebagai ornamen arsitektural juga sebagai bukaan untuk keluar masuknya udara.

4.10 Perspektif Eksterior







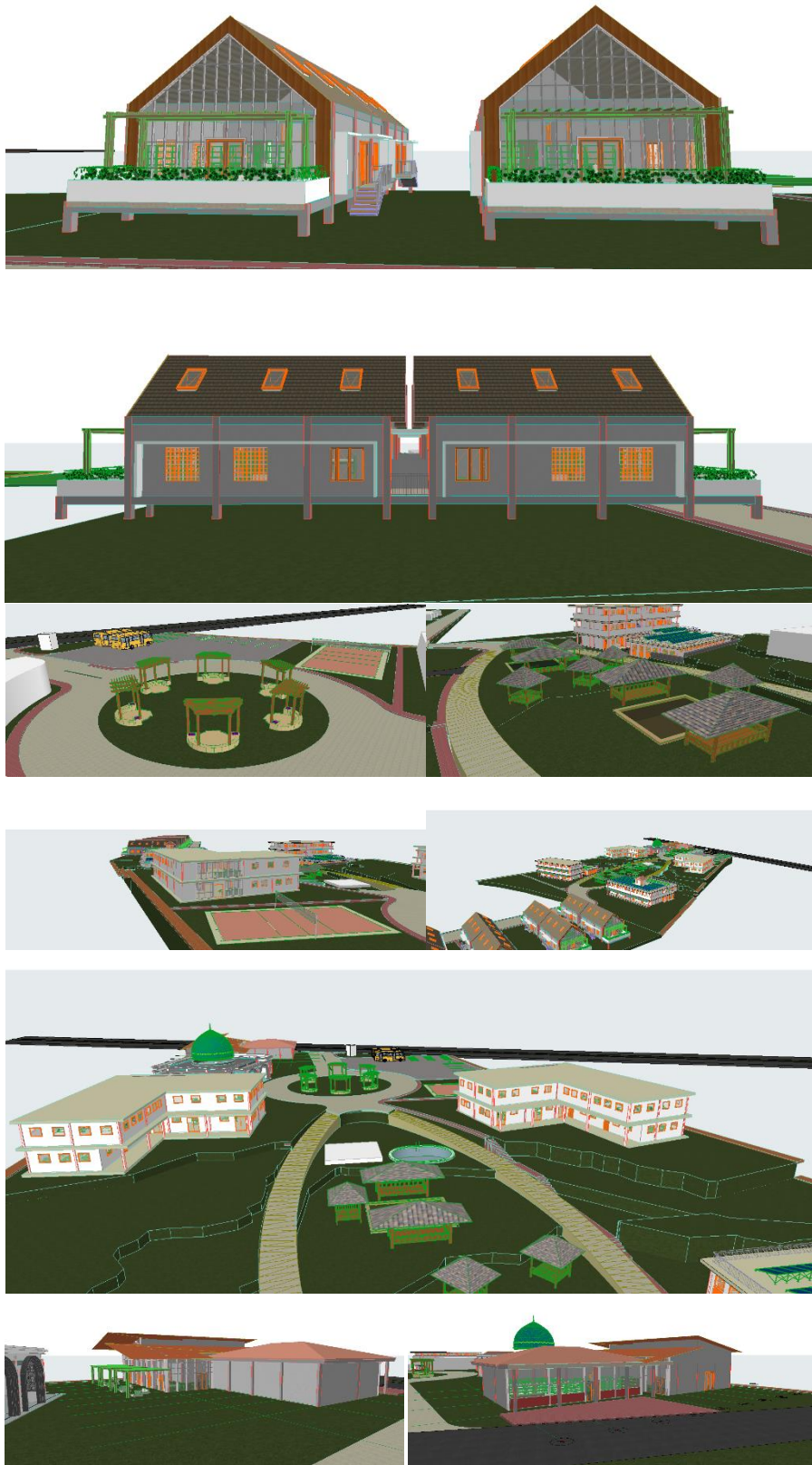

Gambar 4.23 Perspektif Eksterior Ponpes Subulana.
Sumber: Penulis (2019)

4.11 Perspektif Interior

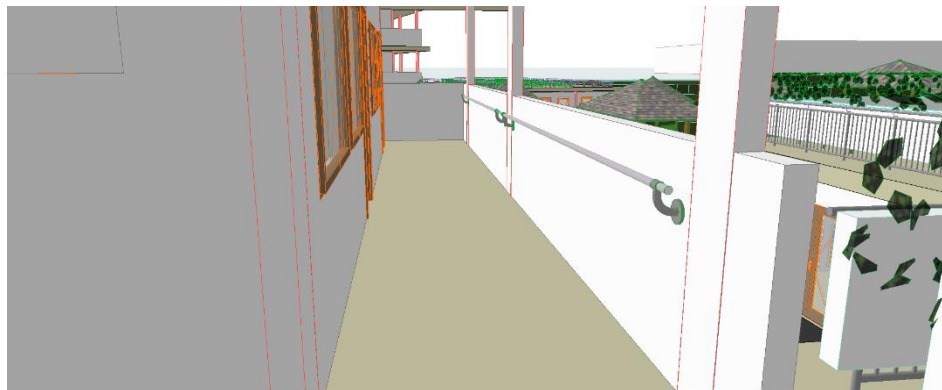
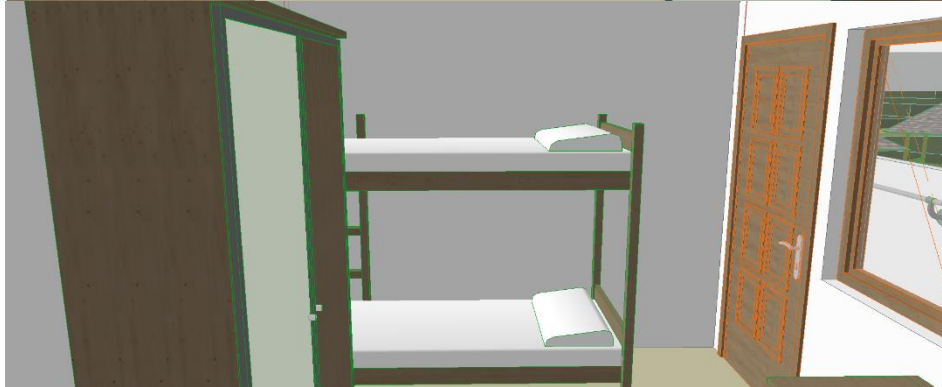

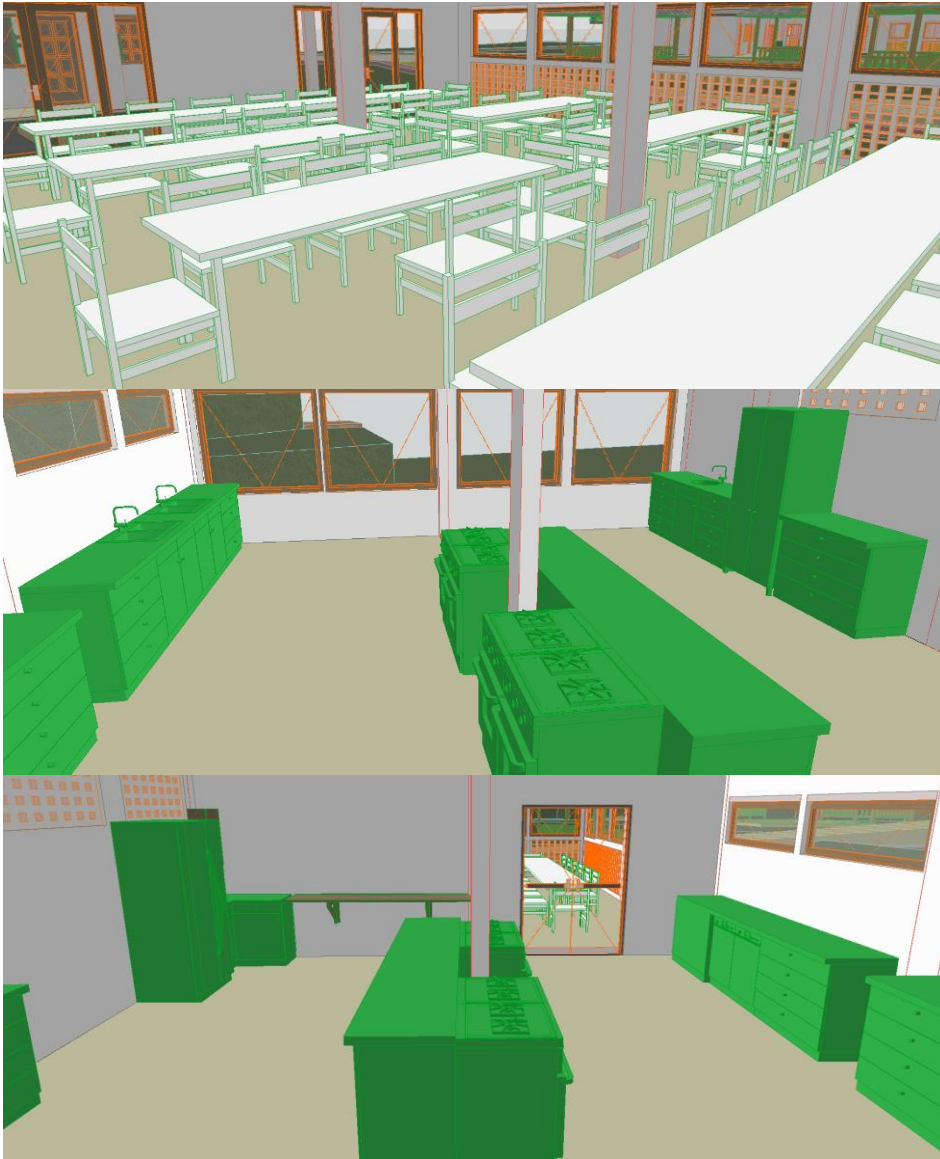

Gambar 4.24 Perspektif Interior Ponpes Subulana.
Sumber: Penulis (2019)