

LAMPIRAN

Lampiran 1. Daftar Harga Bahan

No.	JENIS BAHAN	SATUAN	HARGA
			SATUAN (Rp.)
1	Air	ltr	50.00
2	Pasir urug	m3	55,000.00
3	Batu putih urug	m3	80,000.00
4	Batu belah putih 15/20	m3	120,000.00
5	Batu keprus	m3	110,000.00
6	Kapur pasang	m3	110,000.00
7	Pasir Pasang (Progo)	m3	100,000.00
8	Batu pecah (split) 2/3	m3	135,000.00
9	Krikil/kroco	m3	110,000.00
10	Portland semen (40 Kg)	zak	55,000.00
11	Portland semen	kg	1,300.00
12	Semen warna	kg	2,350.00
13	Bata merah besar	bj	600.00
14	Bataco	bj	4,000.00
15	Genteng pres plentong	bj	3,000.00
16	Nok Genteng plentong	Bj	3,000.00
17	Nok Genteng Paris	Bh	3,000.00
18	Nok Genteng Besar Beton warna	Bh	24,000.00
19	Genteng beton warna (type vlaat)	Bj	8,000.00
20	Kerpus beton warna	Bj	8,000.00

Lanjutan Lampiran 1. Daftar Harga Bahan

NO	JENIS BAHAN	SATUAN	HARGA
21	Asbes gelombang kecil (3,00 x1,05 m) x 4mm	Lbr	80,000.00
22	Asbes gelombang besar (3,00 x1,02 m) x 5mm	Lbr	95,000.00
23	Asbes semen polos 1,00 x 1,00 m	Lbr	25,000.00
24	Nok asbes gelombang besar	Set	38,000.00
25	Nok asbes gelombang kecil	Set	29,000.00
26	Atap Polykarbonat	m2	295,800.00
27	Plat GRC (1,00 X 1,00)m	m2	80,000.00
28	Kalsiboard 3,5 mm (1,2 x 2,40)	Lbr	100,000.00
29	Gypsum 9 mm (1,2 x 2,40)	Lbr	75,000.00
30	Plepet 1/4	m'	90,000.00
31	Rangka hollow 4x4 cm	m'	8,000.00
32	Rangka hollow 2x4 cm	m'	7,000.00
33	List profil gypsum 12 cm	m'	8,000.00
34	Kasa gypsum	Rol	10,000.00
35	Tepung gypsum	Kg	20,000.00
36	Alkasit	Kg	45,000.00
37	Kawat penggantung	m'	3,000.00
38	Seng plat BJLS 20 lebar 70 cm	m'	55,000.00
39	Nok seng produk lokal	m'	31,500.00
40	Alluminium plat	m2	1,090,000.00
41	Besi rangka	Kg	8,000.00
42	Besi Tulangan polos	Kg	5,500.00

Lanjutan Lampiran 1. Daftar Harga Bahan

NO	JENIS BAHAN	SATUAN	HARGA
43	Besi Tulangan ulir	Kg	5,600.00
44	Bendrat	Kg	15,000.00
45	Paku	Kg	17,000.00
46	Paku eternit/pepet (1 cm - 2,5 cm)	Kg	20,000.00
47	Paku skrup	Kg	25,000.00
48	Paku payung	Kg	20,000.00
49	Begel, bout, angkur (baja strip)	Kg	9,000.00
50	Baja strip 2 x 3 (Teralis besi)	Kg	8,000.00
51	Kayu bekisting papan	m3	700,000.00
52	Kayu tahun balok	m3	1,800,000.00
53	Kayu dolken	Btg	8,000.00
54	Kayu jati lokal balok	m3	8,000,000.00
55	Kayu jati lokal papan	m3	9,000,000.00
56	Kayu kamper balok	m3	1,400,000.00
57	Kayu kamper papan	m3	1,700,000.00
58	Kayu Bengkirai balok	m3	1,400,000.00
59	Kayu Bengkirai papan	m3	1,700,000.00
60	Kayu Kruing balok	m3	1,400,000.00
61	Kayu Kruing papan	m3	1,700,000.00
62	Usuk kruing 5/7	m3	1,500,000.00
63	Usuk bengkirai 5/7	m3	1,700,000.00
64	Reng jati lokal 2/3	m3	3,000,000.00

Lanjutan Lampiran 1. Daftar Harga Bahan

NO	JENIS BAHAN	SATUAN	HARGA
65	Reng jati lokal 3/4	m3	3,000,000.00
66	Reng bengkirai 2/3	m3	1,400,000.00
67	Reng bengkirai 3/4	m3	2,000,000.00
68	Triplek 6 mm	Lbr	120,000.00
69	List profil kayu 5 cm	m'	16,000.00
70	Panel Kayu bangkirai 2 cm	m3	1,500,000.00
71	Lem kayu	Kg	20,000.00
72	Meni kayu	Kg	20,000.00
73	Meni besi	Kg	25,000.00
74	Minyak Cat	kg	15,000.00
75	Thinner	ltr	15,000.00
76	Minyak bekisting	ltr	15,000.00
77	Air	liter	100.00
78	Cat kayu (kw. EMCO)	kg	55,000.00
79	Cat tembok (kw. CATYLAC)	kg	25,000.00
80	Cat besi	kg	55,000.00
81	Plamur kayu	kg	20,000.00
82	Plamur tembok	kg	20,000.00
83	Kuas	bh	15,000.00
84	Ampelas	lbr	8,000.00
85	Keramik 25/40 motif	bh	4,000.00
86	Keramik 25/25 motif	bh	3,000.00

Lanjutan Lampiran 1. Daftar Harga Bahan

NO	JENIS BAHAN	SATUAN	HARGA
87	Keramik30/30 motif	bh	6,000.00
88	Keramik 30/30 polos	bh	5,000.00
89	Keramik 30/30 tekstur	bh	5,500.00
90	Keramik 40/40 motif	bh	12,000.00
91	Keramik 40/40 tekstur	bh	11,000.00
92	Keramik 60/60 motif	bh	30,000.00
93	Keramik 60/60 tekstur	bh	29,000.00
94	Batu tempel hitam alur	m2	80,000.00
95	Konblok segi enam besar tebal 6 cm K-200	m2	110,000.00
96	Konblok segi enam besar tebal 8 cm K - 300	m2	120,000.00
97	Kaca polos 5 mm	m2	75,000.00
98	Klosed duduk	bh	1,500,000.00
98	Klosed jongkok	bh	300,000.00
99	Bak mandi porselin 60x60x60 cm	bh	1,600,000.00
100	Wastafel	bh	900,000.00
101	Floor drain	bh	45,000.00
102	Pipa PVC AW dia. 4"	m'	42,500.00
103	Pipa PVC AW dia. 3"	m'	27,500.00
104	Pipa PVC AW dia. 2.5"	m'	21,250.00
105	Pipa PVC AW dia. 3/4"	m'	5,000.00
106	Kran 3/4"	bh	35,000.00
107	Gate Valve 1"	bh	200,000.00

Lanjutan Lampiran 1. Daftar Harga Bahan

NO	JENIS BAHAN	SATUAN	HARGA
108	Seal tape	bh	5,000.00
109	Slot pintu	bh	35,000.00
110	Ensel pintu	bh	20,000.00
111	Engsel jendela	bh	15,000.00
112	Spring knife	bh	20,000.00
113	Grendel pintu	bh	20,000.00
114	Grendel jendela	bh	15,000.00
115	Kait angin	bh	30,000.00
116	Handle Jendela	bh	30,000.00
117	Foding gate alur	m2	300,000.00
118	Rolingdoor Alluminium	m2	550,000.00
119	Kusen aluminium 4" Coklat	m'	90,000.00
120	Frame pintu aluminium	m'	90,000.00
121	Frame jendela aluminium	m'	90,000.00
122	Tatapan	m'	20,000.00
123	Karet	m'	5,000.00
124	Lis U	m'	42,000.00
125	Engsel Casm 20"	set	40,000.00
126	Engsel Pintu 4"	bh	30,000.00
127	Kunci pintu Swing	unit	150,000.00
128	Handle pintu Swing	unit	100,000.00
129	Rambuncis	bh	50,000.00

Lanjutan Lampiran 1. Daftar Harga Bahan

NO	JENIS BAHAN	SATUAN	HARGA
130	Kaca bening 8 mm	m2	95,000.00
131	Kaca bening 5 mm	m2	75,000.00
132	Kaca rayband 8 mm	m2	200,000.00
133	Kaca Temper 12 mm	m2	600,000.00
134	Handle stainliees steel	set	350,000.00
135	Kunci pintu tempered	set	750,000.00
136	Kunci Slot	bh	150,000.00
137	Floor hinge	set	1,300,000.00
138	Plat aluminium/Spandrel	m2	400,000.00

Lampiran 3. Daftar Pekerjaan Dan Durasi Pada Pekerjaan Struktur

NO	JENIS PEKERJAAN	VOLUME	SATUAN	DURASI	KETERANGAN
Lantai 1					
1	Foot Plate F1 uk. (1,20 x 1,50) K-225	7.30	m3	20 days	Kritis
2	Foot Plate F2 uk. (1,00 x 1,20) K-225	3.14	m3	10 days	tidak kritis
3	Sloof S2 15/20 K-175	0.71	m3	7 days	tidak kritis
4	Sloof S1 20/25 K-225	6.63	m3	12 days	Kritis
5	Kolom K1 30/50 K-225	7.20	m3	15 days	Kritis
6	Kolom K2 30/40 K-225	1.92	m3	10 days	tidak kritis
7	Kolom praktis 12/12 K-175	0.86	m3	7 days	tidak kritis
8	Balok B1 30/60 K-225	14.04	m3	23 days	Kritis
9	Balok B2 25/40 K-225	7.50	m3	10 days	tidak kritis
10	Balok B3 20/30 K-225	1.44	m3	7 days	tidak kritis
11	Lisplank beton 6/60 K-225	1.87	m3	4 days	tidak kritis
12	Balok latiu 12/15 K- 175	0.09	m3	4 days	tidak kritis
13	Plat lantai tb. 12 cm K-225	32.62	m3	23 days	Kritis
14	Plat tangga tb. 16 cm K-225	2.71	m3	3 days	tidak kritis
15	Pondasi tangga 100 x 120 cm K-225	1.23	m3	3 days	tidak kritis
16	Balok bordes 20/30 K-225	0.15	m3	3 days	tidak kritis

Lanjutan Lampiran 3. Daftar Pekerjaan Dan Durasi Pada Pekerjaan Struktur

Lantai 2					
17	Kolom K3 20/30 K-225	3.84	m3	12 days	Kritis
18	Peninggian kolom lama 20/30 K-225	0.72	m3	5 days	tidak kritis
19	Sloof peninggian lantai S2 15/20 K- 175	2.32	m3	5 days	tidak kritis
20	Kolom praktis 12/12 K-175	1.01	m3	4 days	tidak kritis
21	Balok latiu 12/15 K-175	0.44	m3	4 days	Kritis
22	Balok ring R1 20/35 K-225	2.07	m3	5 days	kritis
23	Balok ring R2 20/25 K-225	6.75	m3	3 days	tidak kritis
24	Balok ring R3 15/20 K-175	0.45	m3	3 days	tidak kritis

Lampiran 4. Hubungan Predocessor Pekerjaan

Task Name	Duration	Start	Finish	Predecessors
STRUKTUR LANTAI 1&2	70 days	Tue 8/22/17	Mon 10/30/17	
START	0 days	Tue 8/22/17	Tue 8/22/17	
PEKERJAAN BETON BERTULANG LT1	49 days	Tue 8/22/17	Mon 10/9/17	
Foot Plate F1 uk. (1,20 x 1,50) K-225	20 days	Tue 8/22/17	Sun 9/10/17	2
Foot Plate F2 uk. (1,00 x 1,20) K-225	10 days	Tue 8/22/17	Thu 8/31/17	4SS
Sloof S2 15/20 K-175	7 days	Sat 8/26/17	Fri 9/1/17	5SS+4 days
Sloof S1 20/25 K-225	12 days	Wed 8/30/17	Sun 9/10/17	4SS+8 days
Kolom K1 30/50 K-225	15 days	Wed 9/6/17	Wed 9/20/17	7SS+7 days
Kolom K2 30/40 K-225	8 days	Wed 9/6/17	Wed 9/13/17	8SS
Kolom praktis 12/12 K-175	5 days	Wed 9/6/17	Sun 9/10/17	8SS
Balok B1 30/60 K-225	23 days	Sat 9/16/17	Sun 10/8/17	8SS+10 days
Balok B2 25/40 K-225	10 days	Fri 9/29/17	Sun 10/8/17	11FF
Balok B3 20/30 K-225	7 days	Mon 10/2/17	Sun 10/8/17	12FF
Lisplank beton 6/60 K-225	4 days	Thu 10/5/17	Sun 10/8/17	16FF
Balok latiu 12/15 K- 175	4 days	Tue 9/19/17	Fri 9/22/17	8SS+13 days
Plat lantai tb. 12 cm K-225	23 days	Sat 9/16/17	Sun 10/8/17	11FF
Plat tangga tb. 16 cm K-225	3 days	Sat 10/7/17	Mon 10/9/17	18
Pondasi tangga 100 x 120 cm K-225	3 days	Wed 10/4/17	Fri 10/6/17	16SS+18 days
Balok bordes 20/30 K-225	3 days	Sat 10/7/17	Mon 10/9/17	17FF

Lanjutan Lampiran 4. Hubungan Predoessor Pekerjaan

Task Name	Duration	Start	Finish	Predecessors
PEKERJAAN BETON BERTULANG LT2	21 days	Tue 10/10/1 7	Mon 10/30/17	
Kolom K3 20/30 K-225	12 days	Tue 10/10/1 7	Sat 10/21/17	16FS+1 day
Peninggian kolom lama 20/30 K-225	5 days	Tue 10/10/1 7	Sat 10/14/17	21SS
Sloof peninggian lantai S2 15/20 K-175	5 days	Tue 10/10/1 7	Sat 10/14/17	21SS
Kolom praktis 12/12 K-175	4 days	Sun 10/15/1 7	Wed 10/18/17	23
Balok latiu 12/15 K-175	4 days	Fri 10/27/1 7	Mon 10/30/17	26
Balok ring R1 20/35 K-225	5 days	Sun 10/22/1 7	Thu 10/26/17	21
Balok ring R2 20/25 K-225	3 days	Tue 10/24/1 7	Thu 10/26/17	26FF
Balok ring R3 15/20 K-175	3 days	Tue 10/24/1 7	Thu 10/26/17	27FF
FINISH	0 days	Mon 10/30/1 7	Mon 10/30/17	25,24,15,22,19,28,6, 9,10,13,14

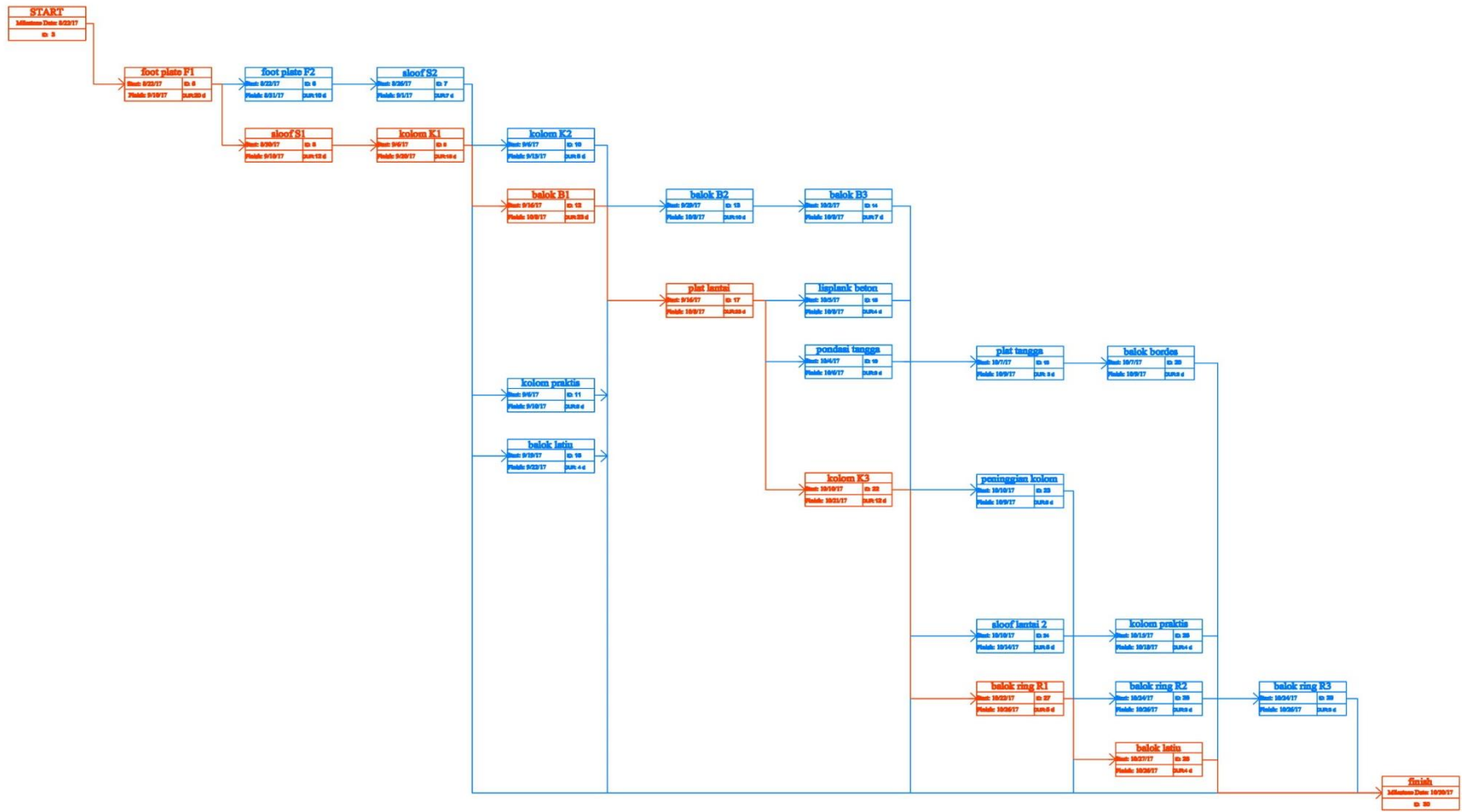

Lampiran 5. Biaya Cost Slope Pada penambahan tenaga kerja

Nama pekerjaan	Sebelum crashing			Setelah crashing			Slope	Total Slope
	Durasi	Resource	Harga	Durasi	Resource	Harga		
Pembesian Foot Plate F1 uk. (1,20 x 1,50) K-225	15		Rp 787,356.42	7		Rp 1,855,000.00	Rp 133,455.45	Rp 1,067,643.58
		0.41849			1			
		0.41849			1			
		0.04185			1			
		0.01794			1			
Pembesian Sloof S1 20/25 K-225	10		Rp1,156,528.12	5		Rp 1,900,000.00	Rp 148,694.38	Rp 743,471.88
		0.92206			2			
		0.92206			2			
		0.09221			1			
		0.03952			1			
Bekisting Sloof S1 20/25 K-225	8		Rp2,022,281.25	5		Rp 3,025,000.00	Rp 334,239.58	Rp 1,002,718.75
		2.73281			5			
		1.36641			3			
		0.13664			1			
		0.13664			1			
Pembesian Kolom K1 30/50 K-225	10		Rp1,057,463.20	5		Rp 1,900,000.00	Rp 168,507.36	Rp 842,536.80

Lanjutan Lampiran 5. Biaya Cost Slope Pada penambahan tenaga kerja

		0.84308			2			
		0.84308			2			
		0.08431			1			
		0.03613			1			
Pembesian Balok B1 30/60 K-225	17		Rp1,870,297.16	8		Rp 3,040,000.00	Rp 129,966.98	Rp 1,169,702.84
		0.87713			2			
		0.87713			2			
		0.08771			1			
		0.03759			1			
Bekisting Balok B1 30/60 K-225	15		Rp2,999,997.00	9		Rp 4,410,000.00	Rp 235,000.50	Rp 1,410,003.00
		2.16216			4			
		1.08108			2			
		0.10811			1			
		0.10811			1			
Pembesian Plat lantai tb. 12 cm K-225	20		Rp4,041,402.57	11		Rp 4,785,000.00	Rp 82,621.94	Rp 743,597.43
		1.61104			3			
		1.61104			2			
		0.1611			1			
		0.06904			1			
Bekisting Plat lantai tb. 12 cm K-225	15		Rp8,364,607.02	11		Rp 10,395,000.00	Rp 507,598.25	Rp 2,030,392.98

Lanjutan Lampiran 5. Biaya Cost Slope Pada penambahan tenaga kerja

		6.02855			9			
		3.01427			5			
		0.30143			1			
		0.30143			1			
Pembesian Kolom K3 20/30 K-225	7		Rp 842,092.35	4		Rp 1,520,000.00	Rp 225,969.22	Rp 677,907.65
		0.9591			2			
		0.9591			2			
		0.09591			1			
		0.0411			1			
Pembesian Balok latiu 12/15 K-175	3		Rp 99,491.80	1		Rp 265,000.00	Rp 82,754.10	Rp 165,508.20
		0.2644			1			
		0.2644			1			
		0.02644			1			
		0.01133			1			
Pembesian Balok ring R1 20/35 K-225	4		Rp 359,210.78	3		Rp 795,000.00	Rp 435,789.22	Rp 435,789.22
		0.71597			1			
		0.71597			1			
		0.0716			1			
		0.03068			1			
TOTAL SLOPE								Rp 10,289,272.33

Lampiran 6. Rekapitulasi RAB

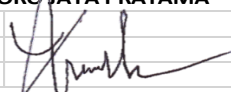
		CV. GORO JAYA PRATAMA GENERAL CONTRACTOR - SUPLIER PERUM KORPRI B.7 No.1 Sukarame Bandar Lampung - Telp/ Fax : +62-721-706447	
REKAPITULASI			
PERHITUNGAN CONTRACT CHANGE ORDER (CCO)			
KEGIATAN	: PENGADAAN SARANA DAN PRASARANA DI LINGKUNGAN MAHKAMAH AGUNG		
PEKERJAAN	: RENOVASI RUANG SIDANG		
LOKASI	: KAB. GUNUNG KIDUL		
THN. ANGGARAN	: 2017		
NO.	MACAM PEKERJAAN	JUMLAH HARGA (Rp.)	
A	PEKERJAAN PERSIAPAN	Rp.	24,276,339.00
		Rp.	24,276,339.00
B	PEKERJAAN LANTAI I		
	I PEKERJAAN TANAH DAN URUGAN	Rp.	18,118,305.56
	II PEKERJAAN PASANGAN DAN PLESTERAN	Rp.	114,009,236.24
	III PEKERJAAN BETON BERTULANG	Rp.	218,172,123.17
	IV PEKERJAAN LANTAI DAN PELAPIS DINDING	Rp.	96,111,459.34
	V PEKERJAAN PINTU DAN JENDELA	Rp.	123,956,492.00
	VI PEKERJAAN LANGIT-LANGIT	Rp.	68,946,575.00
	VII PEKERJAAN SANITASI & INSTALASI AIR BERSIH	Rp.	15,875,162.50
	VIII PEKERJAAN MEKANIKAL DAN ELEKTRIKAL	Rp.	27,040,000.00
	IX PEKERJAAN CAT	Rp.	46,795,907.53
		Rp.	729,025,261.35
C	PEKERJAAN LANTAI II		
	I PEKERJAAN PASANGAN DAN PLESTERAN	Rp.	92,209,022.90
	II PEKERJAAN BETON BERTULANG	Rp.	55,551,605.33
	III PEKERJAAN LANTAI DAN PELAPIS DINDING	Rp.	77,437,320.23
	IV PEKERJAAN PINTU DAN JENDELA	Rp.	122,503,801.75
	V PEKERJAAN RANGKA ATAP DAN PENUTUP ATAP	Rp.	174,120,904.51
	VI PEKERJAAN LANGIT-LANGIT	Rp.	74,396,145.50
	VII PEKERJAAN SANITASI & INSTALASI AIR BERSIH	Rp.	30,623,788.00
	VIII PEKERJAAN MEKANIKAL DAN ELEKTRIKAL	Rp.	24,530,000.00
	IX PEKERJAAN PENANGKAL PETIR	Rp.	-
	X PEKERJAAN CAT	Rp.	31,042,538.71
		Rp.	682,415,126.92
	JUMLAH (A + B + C)	Rp.	1,435,716,727.27
	PPN 10 %	Rp.	143,571,672.73
	JUMLAH TOTAL	Rp.	1,579,288,400.00
	NILAI KONTRAK AWAL	Rp.	1,579,288,400.00
	TAMBAH KURANG	Rp.	- 0.00
Bandar Lampung, Agustus 2017 CV. GORO JAYA PRATAMA  YOVI ANDIKA Direktur			